

PORTAL

PSK 100 comfort

Parallel slide & tilt hardware
for PVC and timber elements
with 12 mm chamber dimension/airgap.

Window systems

Door systems

Comfort systems

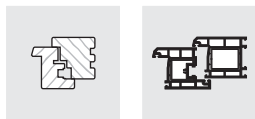

Content

1	GENERAL NOTES.....4	6	PROFILE SECTIONS19
1.1	Target group of this documentation 4	6.1	Top vertical cross-section 19
1.2	Intended use 4	6.2	Bottom vertical cross-section..... 20
1.3	Improper use..... 4		
1.4	Safety notes 4	7	JIGS21
1.5	Help and support 5		
1.6	Directives of the Trade Organisation for Locks and Fittings (Gütegemeinschaft Schlösser und Beschläge e. V.) 5	8	FEEDBACK ON DOCUMENTATION.....22
1.7	Dimensions 5		
1.8	Scheme overview 5		
1.9	Operating sequence 6		
1.10	Operating sticker 6		
1.11	Application diagram 6		
2	PROCESSING SPECIFICATIONS7		
2.1	Size ranges..... 7		
2.2	Abbreviations 7		
3	OVERVIEW OF HARDWARE COMPONENTS 8		
3.1	Hardware components scheme A 8		
3.2	Hardware list hardware components..... 9		
4	ASSEMBLY OF THE HARDWARE COMPONENTS10		
4.1	Installing the running rail and guiding rail... 10		
4.2	Installing the tilt stay 11		
4.3	Installing the bogie wheels 12		
4.4	Installing the connecting rod..... 12		
4.5	Installing the L supporting piece 13		
4.6	Installing the cover rail for the bogie wheels .. 13		
4.7	Inserting the sliding sash and connecting with frame..... 14		
4.8	Releasing and removing the sliding sash from the frame 14		
4.9	Installing the bogie wheels safeguards 15		
4.10	Removing the bogie wheels safeguards..... 16		
4.11	Positioning the trigger..... 16		
4.12	Positioning the stop 17		
5	ADJUSTMENT18		
5.1	Adjusting the tilt stay 18		
5.2	Elevating adjustment of the bogie wheels.. 18		

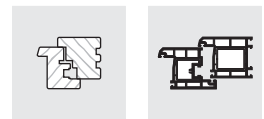

1 General information

1.1 Target group of this documentation

This documentation is intended for use by specialists only. All work described in this document is to be performed by experienced professionals with training and practice in the assembly, installation and maintenance of PORTAL hardware as the safe and professional assembly of the PORTAL hardware is not possible without the relevant expertise. Keep these assembly instructions in a safe place.

1.2 Intended use

- The parallel sliding tilting hardware PSK 100 comfort for use in windows or patio doors with PVC profiles.
- Sash weight max. 100 kg.
- The PSK 100 comfort is intended for use in permanent buildings.
- The PSK 100 comfort allows the horizontal opening and closing of windows and patio doors from profiles for parallel slide & tilt elements.
- The parallel slide & tilt elements must be installed vertically, in no circumstances in a sloping position.

1.3 Improper use

- The hardware components described in these assembly instructions are manufactured from steel, zinc plated and then treated with a special process.
- They must not be used:
 - in wet rooms
 - in environments where the air contains aggressive or corrosive components
 - in environments where the air contains salt
- Please contact your SIEGENIA sales consultant in such cases

1.4 Safety notes

- Maintenance must be carried out on the PSK 100 comfort at least once a year.
See PORTAL maintenance instructions
- For the PSK 100 comfort, the specifications provided by the profile manufacturers or system

owners must also be adhered to with regard to possible restrictions on sash dimensions, sash weights and locking distances.

- Where special manufacturing instructions or fabrication guidelines exist, these must be explicitly adhered to. Functional disorders cannot be excluded otherwise.
- The specifications given for torques must be adhered to.
- Your complete set of hardware should solely be composed of SIEGENIA hardware components. Otherwise functional disorders and damage could occur, for which we accept no liability.
- If special safety aspects must be observed (e.g. for installation in schools, nurseries, hotels, etc.) we recommend the installation of a lockable handle or the use of the PS 200 COMFORT.
- All hardware components must be properly assembled as per the description on pages "Assembly" PSK hardware components and "Adjustment".
- PSK 100 comfort elements may only be surface treated before the hardware components are assembled. Treating these surfaces at a later stage can reduce the functional capacity of the hardware components. In such cases we are not obliged to honour any warranty.
- When block setting, please observe technical guideline no. 3 from the German Glazing Trade [Glaserhandwerk], "Blocking glazing units" [Klotzung von Verglasungseinheiten].
- Never use acid curing sealants as they may cause the hardware components to corrode.
- Never use acidic lubricants and cleaning agents in the vicinity of the guiding rail/the slider.
- Keep the running rail and all rebates free from dirt and debris, especially from deposits of cement and plaster.
- Avoid exposing the hardware directly to water and do not let cleaning agents come into contact with

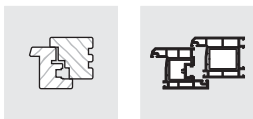

the hardware.

- We recommend cleaning the surfaces with a mild, pH neutral detergent solution in warm water. This will remove most contamination. After cleaning, always rinse the surface of the PVC profile with clear water.

1.5 Help and support

You will find further information on adjustment or processing possibilities under the following QR code.



The QR code sticker can also be found on components of the PSK element. Especially on the inside of the bogie wheels cover caps.

1.6 Directives of the Trade Organisation for Locks and Fittings (Gütegemeinschaft Schlösser und Beschläge e. V.)

The directives of the Trade Organisation for Locks and Fittings (Gütegemeinschaft Schlösser und Beschläge e. V.) provide comprehensive information on the correct operation and maintenance of hardware for windows and patio doors. We deem these directives to be binding.

You can find the latest versions of the directives, in a range of languages here:



<http://www.beschlagindustrie.de/ggsb/richtlinien.asp>

VHBH – Hardware for windows and patio doors
Guidelines/notes on the product and on liability

VHBE – Hardware for windows and patio doors

Guidelines and notes for end users

1.7 Dimensions

All dimensions are nominal values and include the general tolerances (formerly "dimensional variations"). All nominal values are given in mm.

1.8 Scheme overview

Scheme A

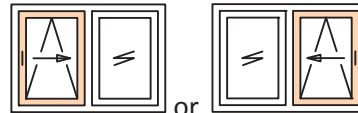

DIN left or DIN right
Scheme A with 1 sliding sash/1 fixed sash*

Scheme G

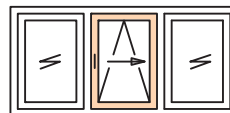

Scheme G with 1 sliding sash/2 fixed sashes*

Scheme C

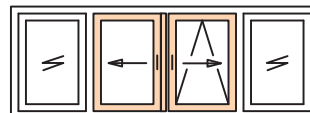

Scheme C with 2 sliding sashes/2 fixed sashes*

Scheme K

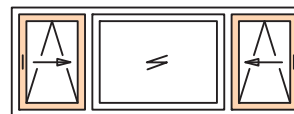

Scheme K with 2 sliding sashes/1 fixed sash*

* Turning sashes instead of the fixed sash are also possible. Turning sashes with rose inside only and removable handle (see handle catalogue).

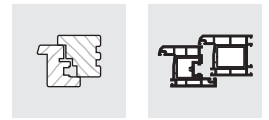

1.9 Operating sequence



Abb. 1: Operating sequence for PSK 100 comfort

1.10 Operating sticker

Attach the operating sticker (slide direction DIN left or DIN right) in a visible position on the installed parallel slide & tilt sash.

The operating sticker is enclosed in the tilt stay carton

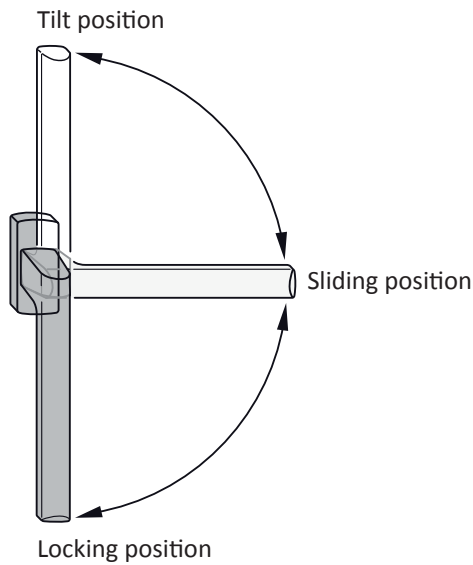

Abb. 2: Operating sticker PS/PSK COMFORT

ATTENTION:

Primary and secondary sashes must be labelled accordingly to prevent faulty operation.

The sliding sashes may be operated only in the order specified below.

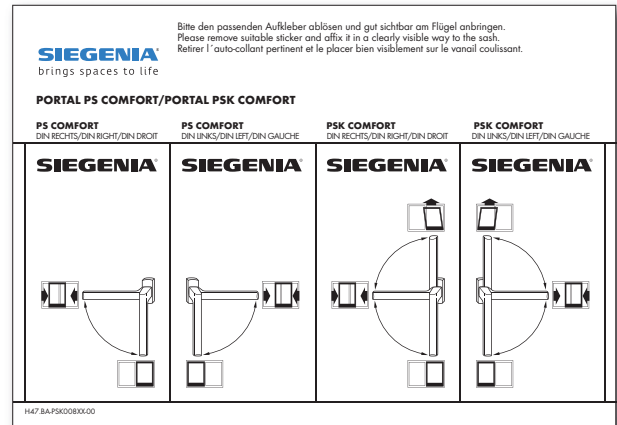
Opening: primary sash first **1.**
then secondary sash **2.**

Closing: secondary sash first **2.**
then primary sash **1.**

1.11 Application diagram

It is essential to observe the application diagram for PS 100 comfort H58.AWD_P_S010EN.

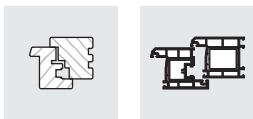

2 Processing specifications

2.1 Size ranges

Scheme version		A	C
Sash rebate width (FFB)	Sliding sash	670-1200	670-1200
Sash rebate height (FFH)	Sliding sash	840-2360	840-2360
Frame width (RAB)	Depends on profile system; determined by the sash rebate width for scheme A	max. 2660	
Frame to sash clearance		125	
Sash weight		max. 100 kg	

Ratio sash height (FH) / sash width (FB) < 2.5 : 1

- SIEGENIA-Construction drawings PVC profiles:
 - PSK 100 comfort
Scheme A
Scheme C
Scheme G
Scheme K
 - The size ranges specified above must not be exceeded.
 - In addition, with regard to the SIEGENIA hardware PSK 100 comfort, the specifications of the profile manufacturers or system owners
- also apply, especially with regard to possible restrictions on sash dimensions, sash weight and locking distance.
- Where special manufacturing instructions or fabrication guidelines exist, these must be explicitly adhered to.
 - See the construction drawing for the respective profile system for further details.
 - Screw heads must not project into the functional area of components. This can lead to material damage and loss of function.

2.2 Abbreviations

The following abbreviations are used in these assembly instructions:

F	Guiding rail	V	Front
FB	Sash width	VSLS	Locking side
FFB	Sash rebate width	VSO	Locking side, top
FH	Sash height	VSU	Locking side, bottom
FFH	Sash rebate height	ZV	Central locking gear:
G	Handle position		
H	Rear		
L	roller		
M	Centre		
MV	Central lock		
OKFF	Finished floor level		
PZ	Profile cylinder		
RAB	Frame width		
RAH	Frame height		
RFB	Frame rebate width		
S-ES	Steel-enhanced security		
S-RS	Steel-roller increased security		
SW	Wrench size		

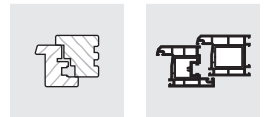

3 Overview of hardware components

3.1 Hardware components presentation scheme A

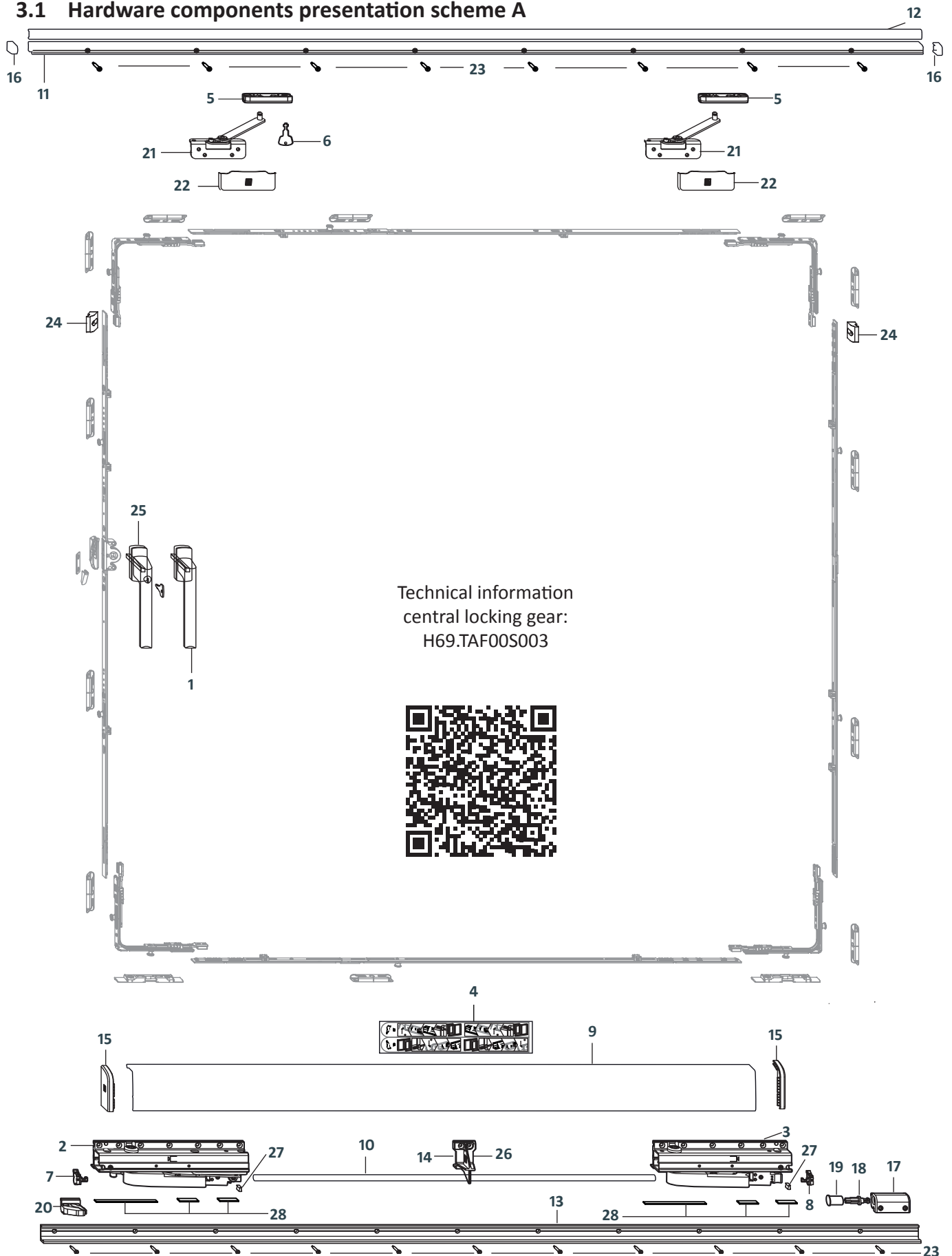



3.2 Hardware list hardware components

Item	Pieces Scheme		Material description	Basis	Material number					
	A	C			Silver	Add-ons for colour				
						RAL 9003 signal white	RAL 8022 brown	F9	old gold	
1	1	2	Handle Si-line PSK	31	PHIJ0010	872086	858264	895634	-5H401_	-5H001_
				35	PHIJ0030	875902	875926	895689	-5H401_	-5H001_
	1	2	Carton bogie wheels PSK COMFORT	right	PMKJ1051-10001_					
				left	PMKJ1052-10001_					
2	1	2	Bogie wheels PSK COMFORT V	Front						
3	1	2	Bogie wheels PSK COMFORT H	Rear						
4	1	1	Sticker PSK bogie wheels safeguard							
5	2	4	Slider PSK COMFORT							
6	1	2	PORTAL key							
7	1	2	Bogie wheels safeguards	Front						
8	1	2	Bogie wheels safeguards	Rear						

depending on sash rebate width (FFB) and frame width (RAB)

Item	A	C	Profile set PSK comfort	Size ¹⁾	FFB	RAB	PMPJ1100	-52501_	-50201_	-51201_	-5H401_	-5H001_						
				Size 87/200	670- 870	up to 2000							PMPJ1110	-52501_	-50201_	-51201_	-5H401_	-5H001_
				Size 107/240	871-1070	2001-2400							PMPJ1110	-52501_	-50201_	-51201_	-5H401_	-5H001_
				Size 130/286	1071-1300	2401-2660							PMPJ1120	-52501_	-50201_	-51201_	-5H401_	-5H001_
9	1	2	Cover rail L															
10	1	2	Connecting rod L															
11	1	2	Guiding rail															
12	1	2	Cover rail F															
13	1	2	Running rail															
14	0-2	0-4	Supporting piece L															
	1	2	Cover cap set PSK 100 comfort	RH and LH	PMAJ1030	-02501_	-00201_	-01201_	-0H401_	-0H001_								
15	2	4	Cover cap L															
16	2	4	Cover cap F															
	1	2	Bag of accessories running rail PSK comfort	right	PMZJ1051	Silver -10001_	Silver -10001_	Silver -10001_	Black -09901_	Black -09901_								
				left	PMZJ1052	-10001_	-10001_	-10001_	-09901_	-09901_								
17	1	2	Stop															
18	1	2	Stop body															
19	1	2	Stop sleeve															
20	1	2	Trigger															
21	2	4	Tilt stay PSK 100	PSKJ0050-100010														
22	2	4	Cover cap S	PKAJ0070	-02505_	-00205_	-01205_	-0H405_										
23	1-20		Drill screw SK H2 3.9x32 DIN7504	for PVC systems	PZUJ0010-00008_													
			Sash lifter; screw SHR AW20 4.1x30	for timber systems	PZUJ0020-00008_													

Accessories

24	2	2	Distance piece	see profile data sheet							
25	1	2	Handle Si-line PSK ABS	lockable	31	PHIJ0020	872093	858318	895641	-	-5H001_
					35	PHIJ0090	-	875957	895696	-	-5H001_
26	1-2	2-4	Supporting piece L	Carton with 100 piece	PZLJ1010-09906_						
27	1	2	Sealing brush set 13 mm	PZUJ0030-00001_							
28	1	2	Distance plate set LW for support of the bogie wheels	Height							
				1 mm	PMZJ1060-00001_						
				2 mm	PMZJ1070-00001_						
				3 mm	PMZJ1080-00001_						
				4 mm	PMZJ1090-00001_						
				8 mm	PMZJ1100-00001_						
	2	4	Distance plate 120 x 11	 Plate height depending on profile; see product catalogue or construction drawing for determination							
	4	8	Distance plate 28 x 11								

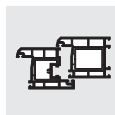

4 Assembly of the hardware components

4.1 Installing the running rail and guiding rail

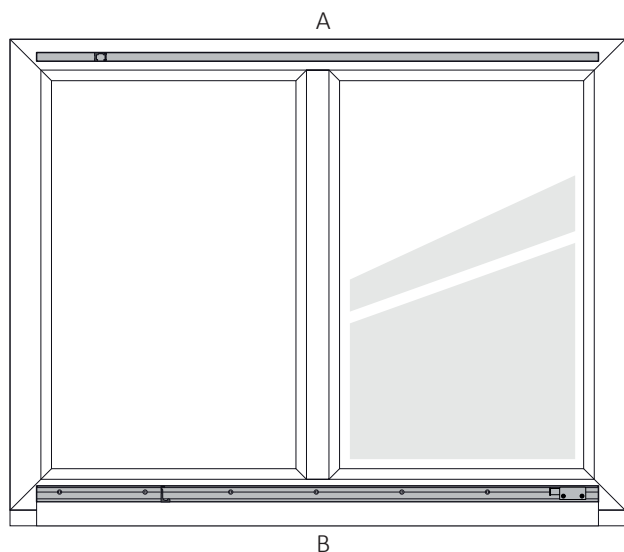

⚠ DANGER

Danger to life due to sliding sash falling out

Wrong position of the guiding and running rail.

- Adhere to the positioning dimensions.



The construction drawing related to the profile must be observed for correct assembly of the guiding and running rail.

A Guiding rail

B Running rail

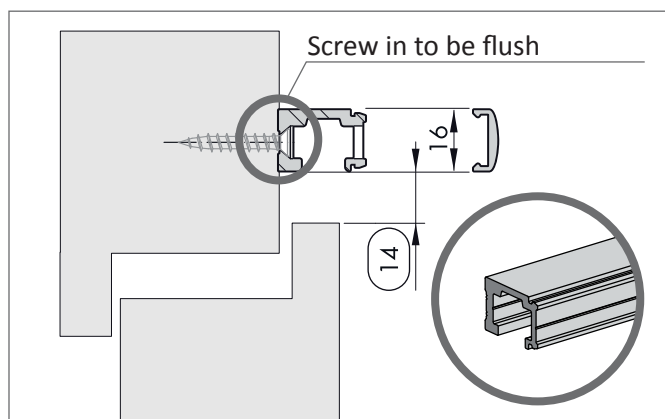

Position the guiding rail.
Observe the construction drawing related to the profile
The screws must be screwed to be flush with the running rail. A projection is not permissible.

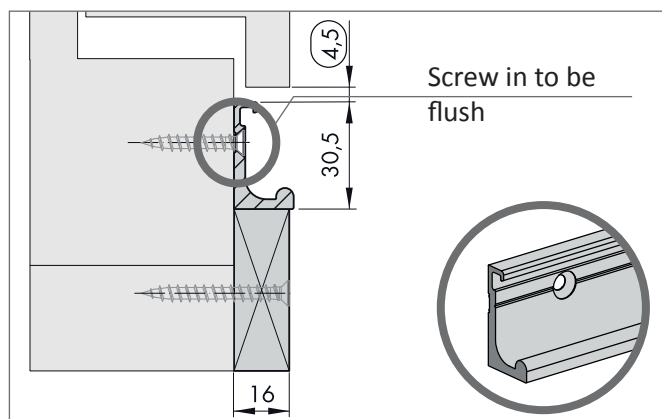

Position the running rail. Observe the construction drawing related to the profile.
Attach load-bearing, end-to-end running rail support when assembling the hardware.
The screws must be screwed to be flush with the running rail. A projection is not permissible

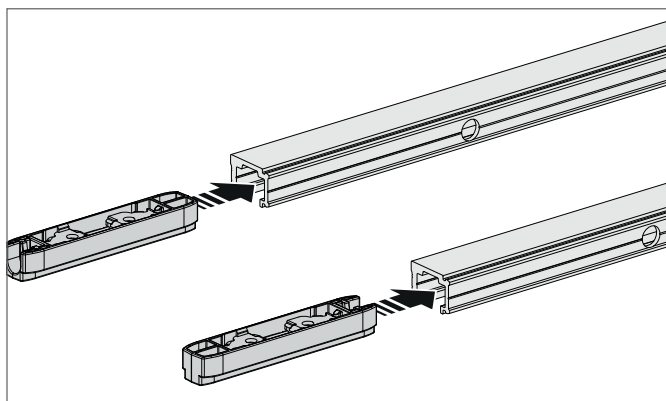

Push both sliders into the guiding rail.

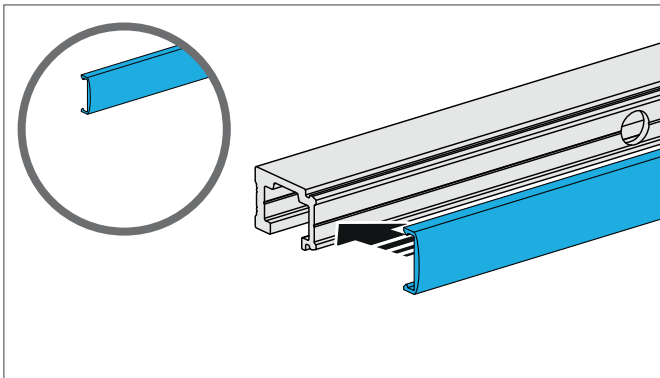
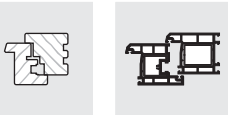

Shorten the cover rail F to the required length and clip onto the guiding rail.

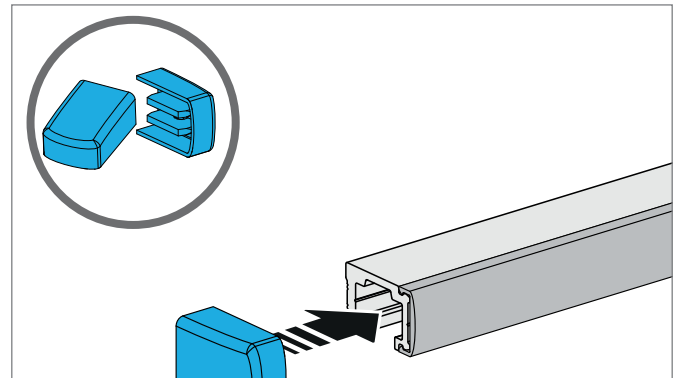

Attach a cover cap F to each end of the guiding rail.

4.2 Installing the tilt stay

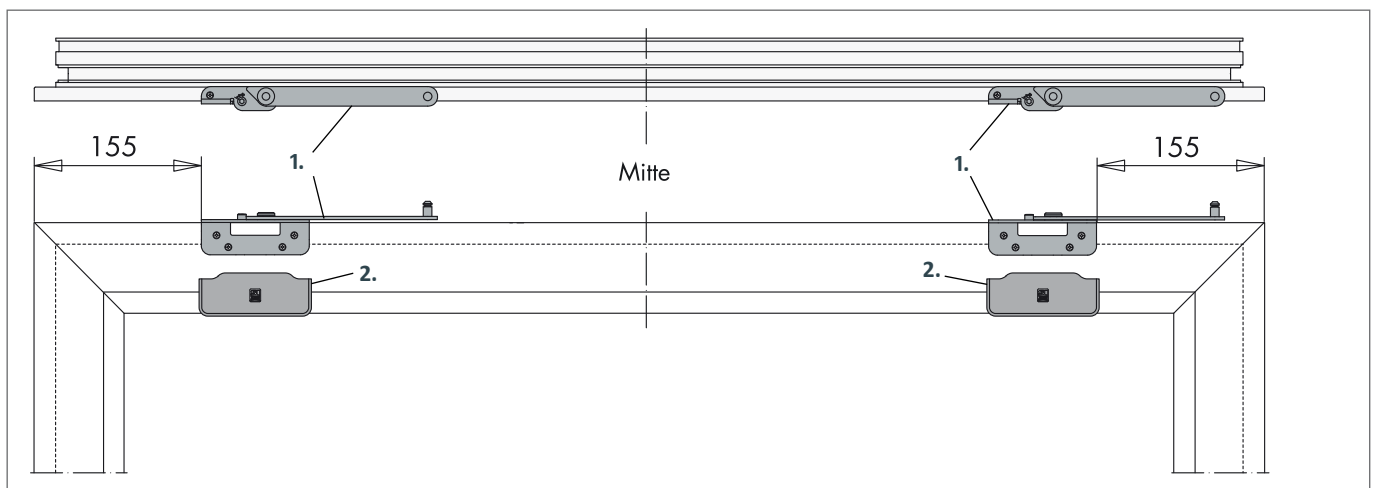

Screw the tilt stay RH and LH to the sash 155 mm from the sash edge (1.).

Clip on cover cap K RH and LH (2.).

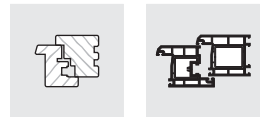

4.3 Installing the bogie wheels

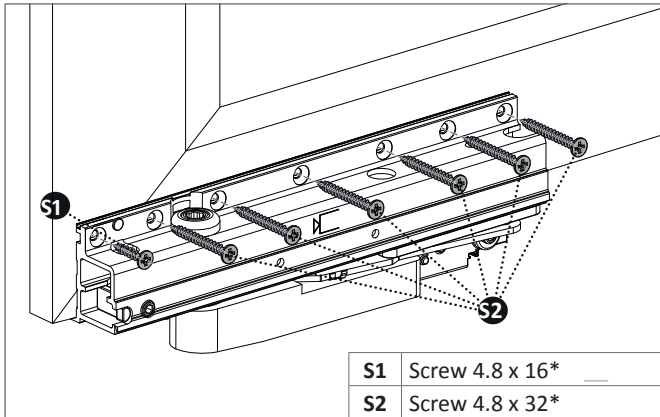

Screw both bogie wheels tightly onto sliding sash according to their position.

*Screw length dependent on profile;

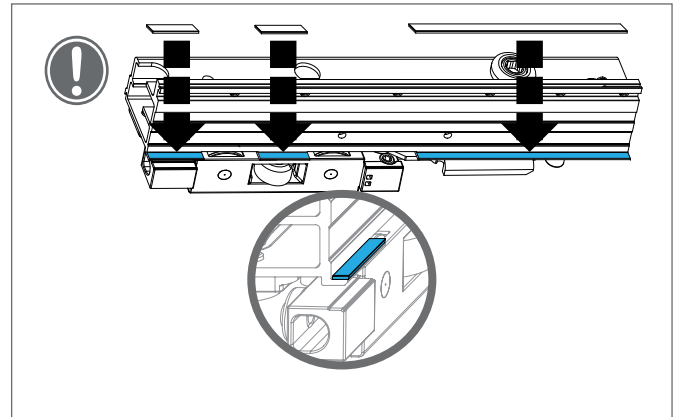

According to the profile system, the optional distance plates must be used (item 28 Overview of hardware components, page 8)

4.4 Installing the connecting rod

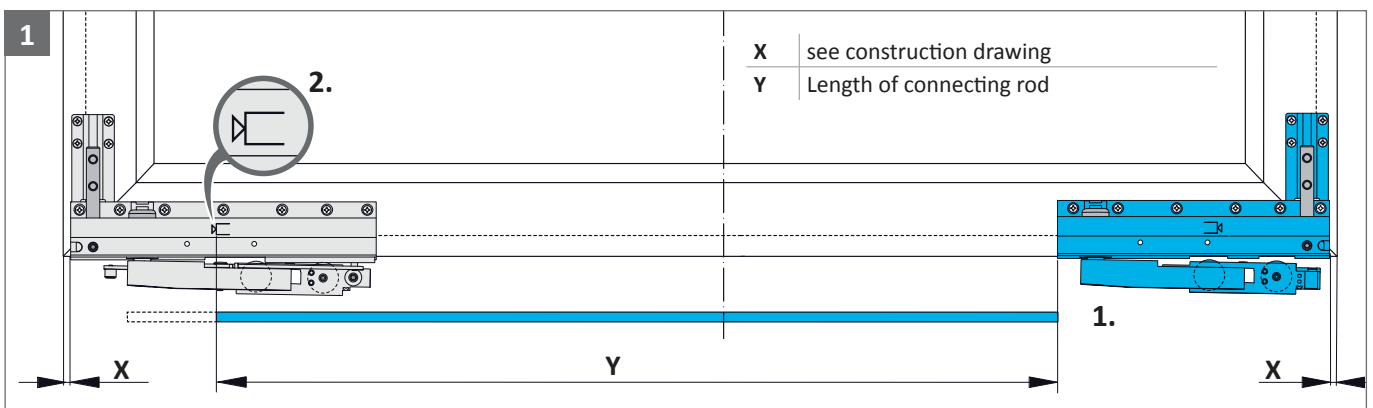

Place connecting rod on the H bogie wheels (1.). Transfer the crop indication on the cropping mark of bogie wheels V, to the connecting rod (2.) and crop the connecting rod.

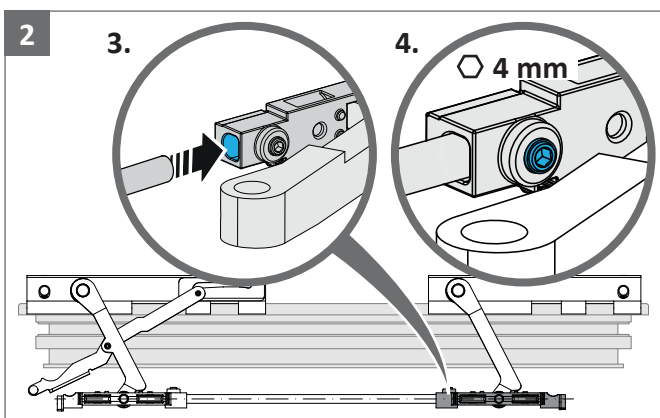

Insert connecting rod into H bogie wheels (3.) and fix with head cap screw (4.). Torque 10-11 Nm.

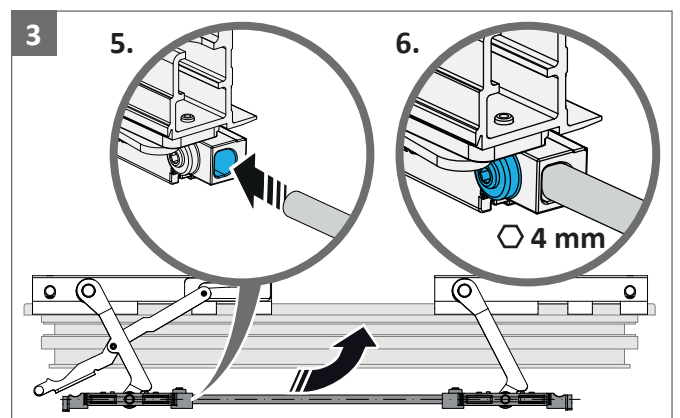

Push connecting rod into bogie wheels V (5.). Bring the bogie wheels housing with connecting rod into the closed position. Now fix the connecting rod with a head cap screw (6.). Torque 10-11 Nm.

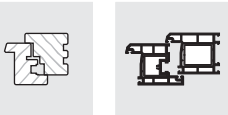

4

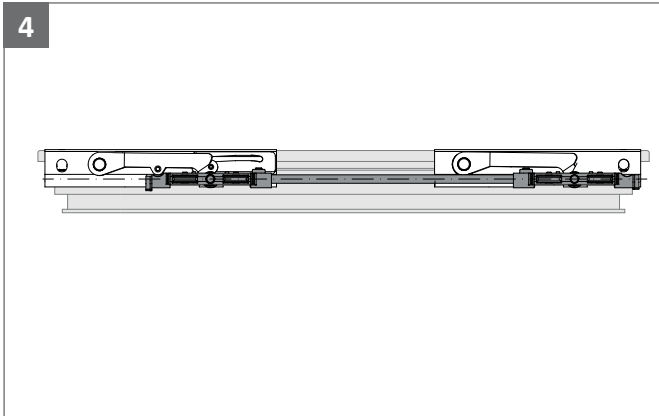

The bogie wheels housing must be standing parallel in the closed position.

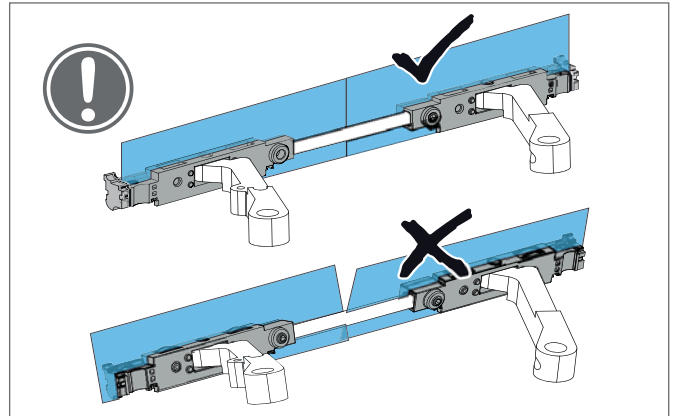

After the fixation of the connecting rod, the bogie wheels housing must align with each other.

4.5 Installing supporting piece L

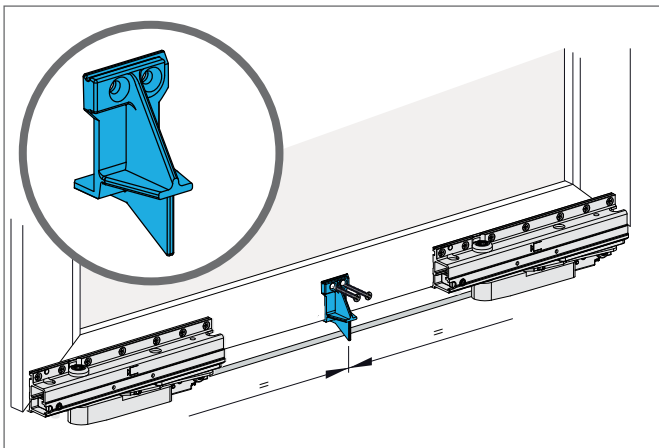

Position supporting piece L for cover rail L centrally and screw into place with 4.8 x 35 screws

4.6 Installing the cover rail for the bogie wheels

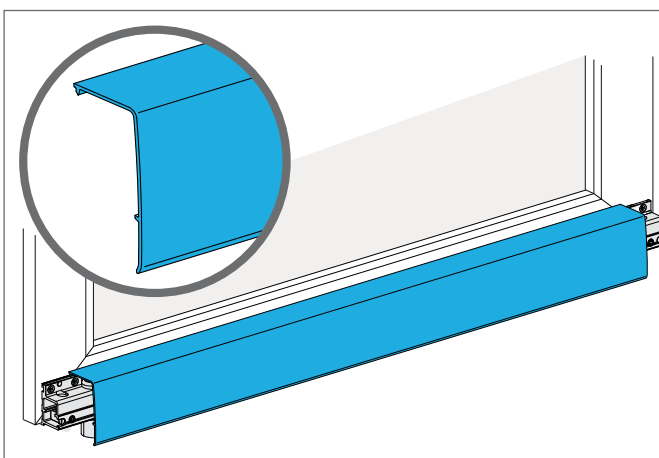

After the sash has been inserted into the frame, attach the cover rail L.

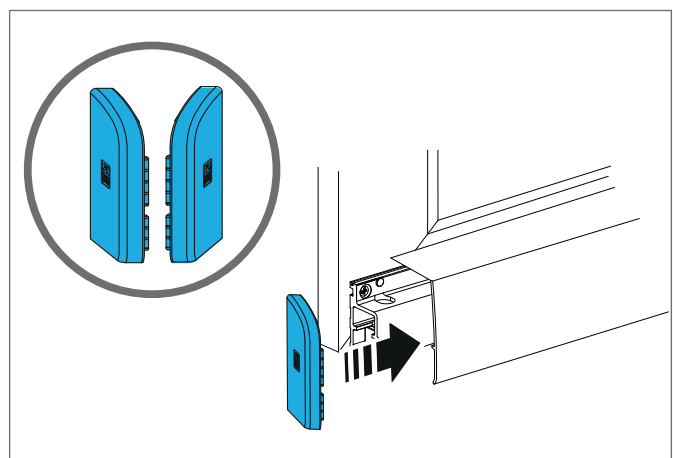

Attach the cover caps L to the respective bogie wheels.

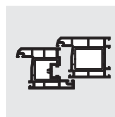

4.7 Inserting the sliding sash and connecting with frame

⚠ DANGER

Danger to life due to sliding sash falling out

Stay arm has not engaged.

- Confirm that the coupling bolt is engaged in the slider by pulling on the stay arm.

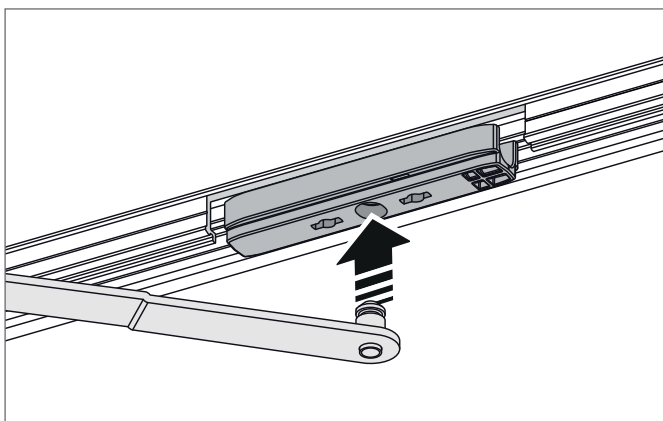

Place stay arms of tilt stay into tilt position. Position the sash on the running rail at an incline and insert the coupling bolt of the stay arms into the slider.

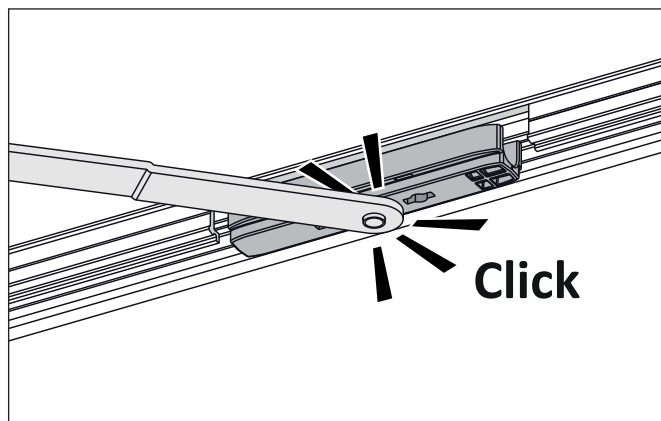

Snap in stay arms of tilt stay into slider. Check firm seating by pulling briefly.

4.8 Releasing and removing the sliding sash from the frame



Only the PORTAL key may be used to release the stay arms in the slider, if other tools are used, there is a danger of damaging the slider.

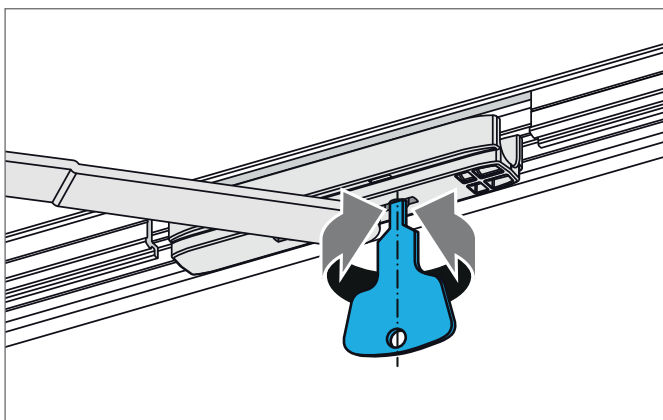

Place stay arms of tilt stay into tilt position. Release stay arms from the slider using the PORTAL key.

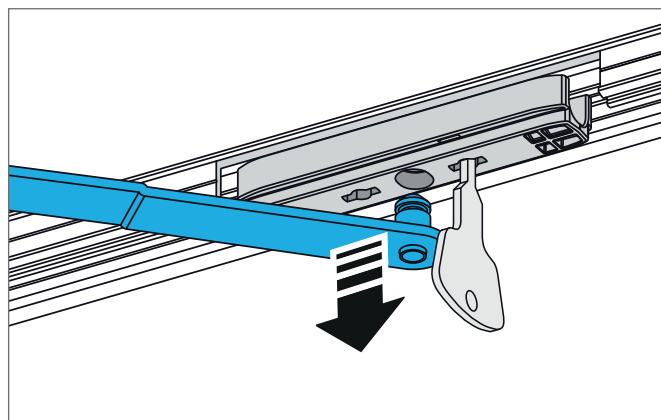

Lift off the stay arms of the tilt stay.



4.9 Installing the bogie wheels safeguards

⚠ DANGER

Danger to life due to sliding sash falling out

Not mounted bogie wheels safeguards.

- The bogie wheels safeguards must be correctly installed in both bogie wheels of a sliding sash.

1

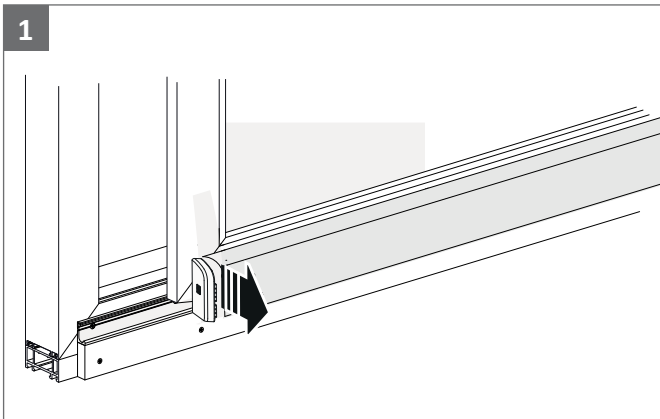

The bogie wheels safeguards can only be installed in a parallel positioned sash.

2

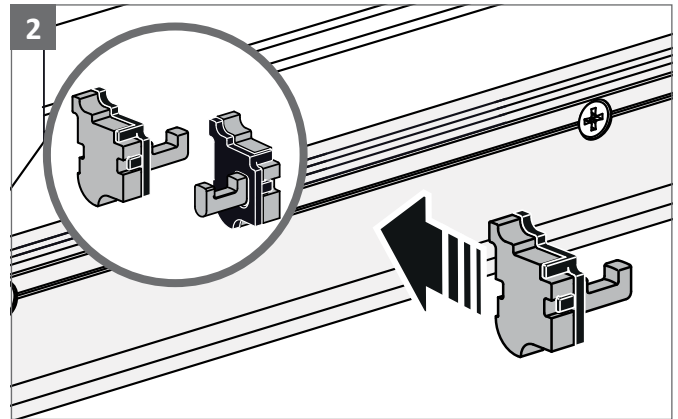

Position the relevant version (RH or LH) of the bogie wheels safeguards in the running rail.

3

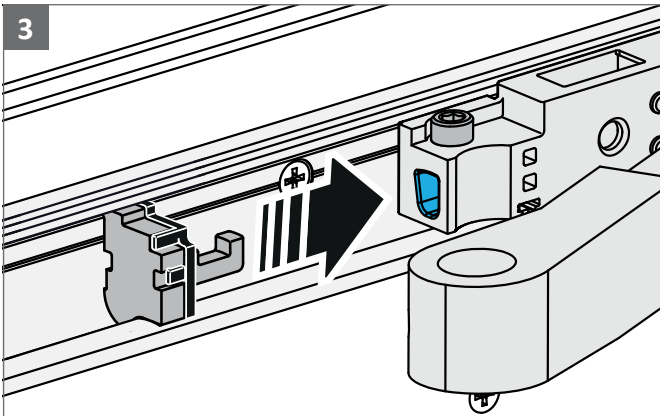

Push bogie wheels safeguards into bogie wheels V and H.

4

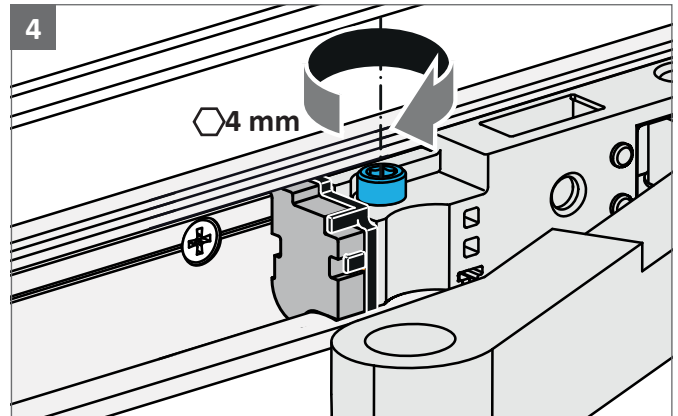

Fix the bogie wheels safeguards in the bogie wheels with a locking screw.

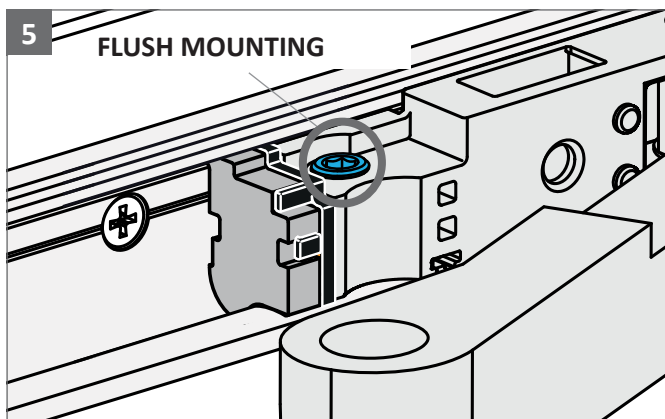
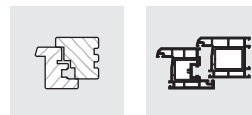

The locking screw must be completely countersunk. Do not overtighten the locking screw, torque max. 3 Nm.

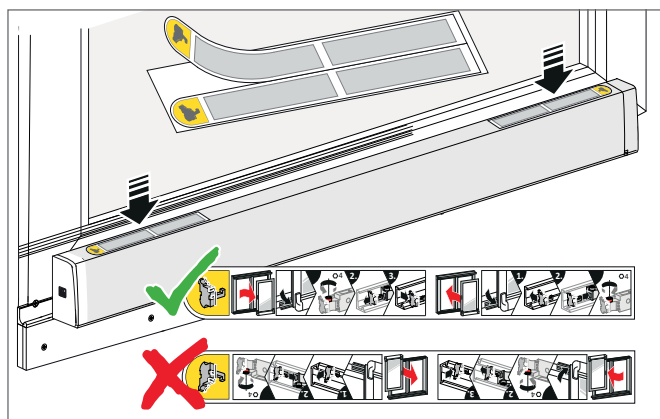

Adhere the notes sticker to the protective foil of the cover rail L. Pay attention to correct orientation of the sticker.

4.10 Removing the bogie wheels safeguards

The removal of the bogie wheels safeguards is carried out in reverse sequence to the installation.

4.11 Positioning the trigger

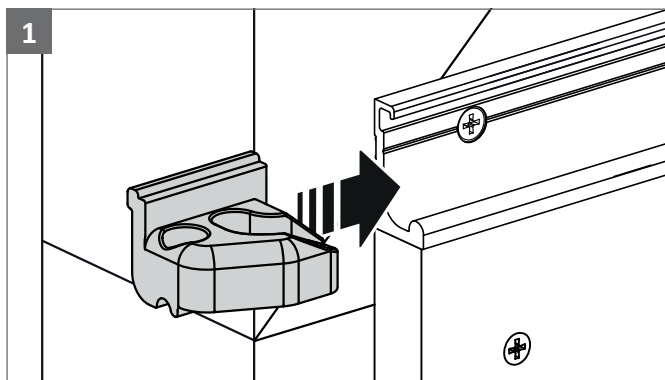

Slide the trigger sideways into the running rail.

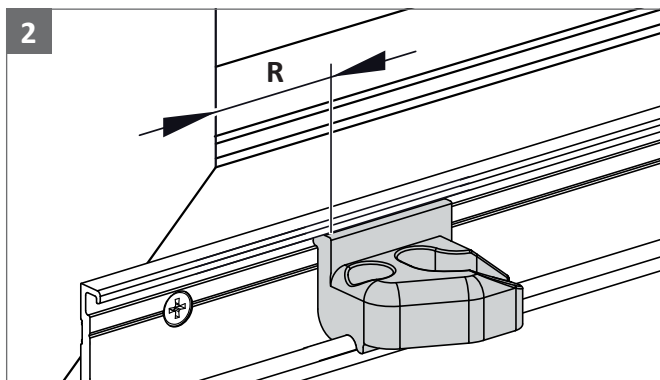

Position the trigger according to the profile.

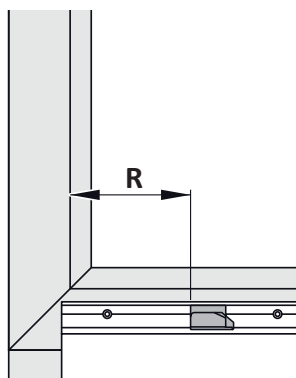

Rebate width	R ¹⁾
18	16
19	15
20	14
21	13
22	12

Dimension R is designed to the position of bogie wheels V.

If the position of bogie wheels V is changed, the position of the trigger must be adapted accordingly.

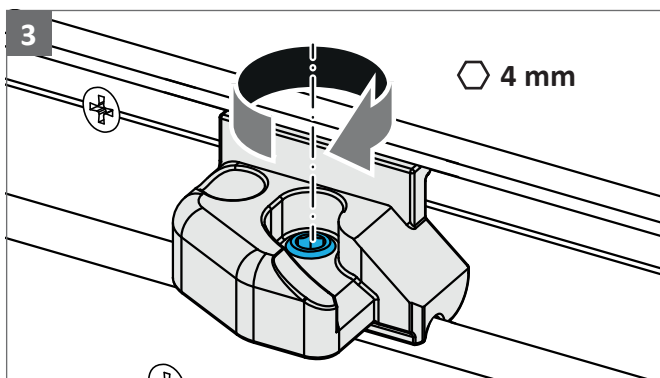

Fix trigger position with head cap screw. Torque max. 3 Nm.

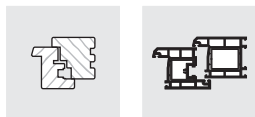

4.12 Positioning the stop

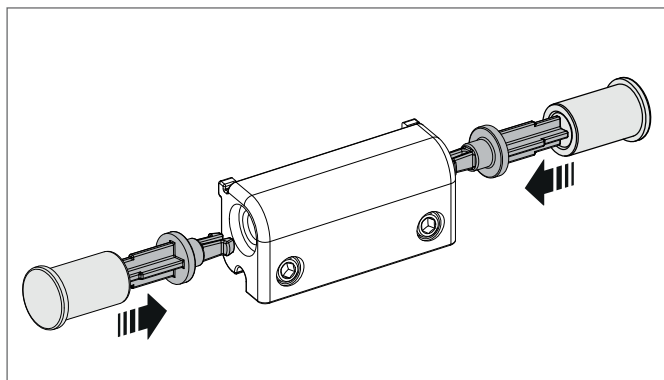

Assemble the stop according to the required DIN direction.

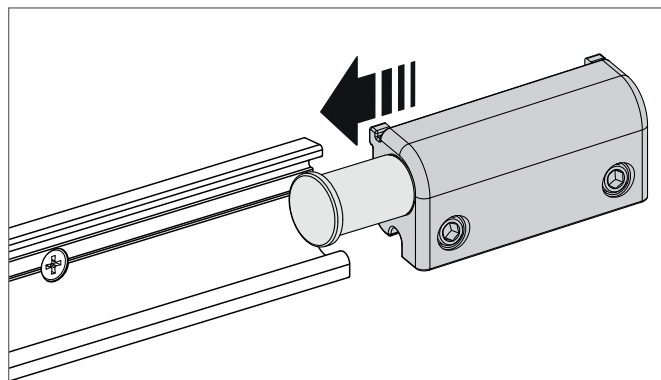

Slide the stop sideways into the running rail.

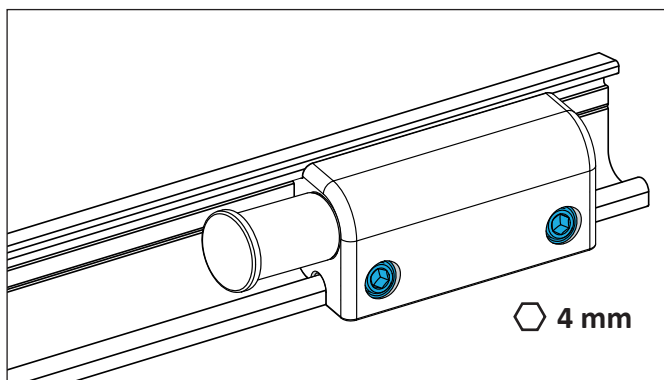

Fix stop into the running rail with Allen key SW 4.
Final positioning only after the sliding sash has been installed. Torque max. 3 Nm. The screws must be fixed at alternating sides to obtain an even torque.

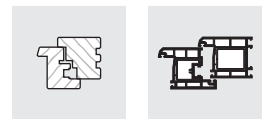

5 Adjustment

5.1 Adjusting the tilt stay

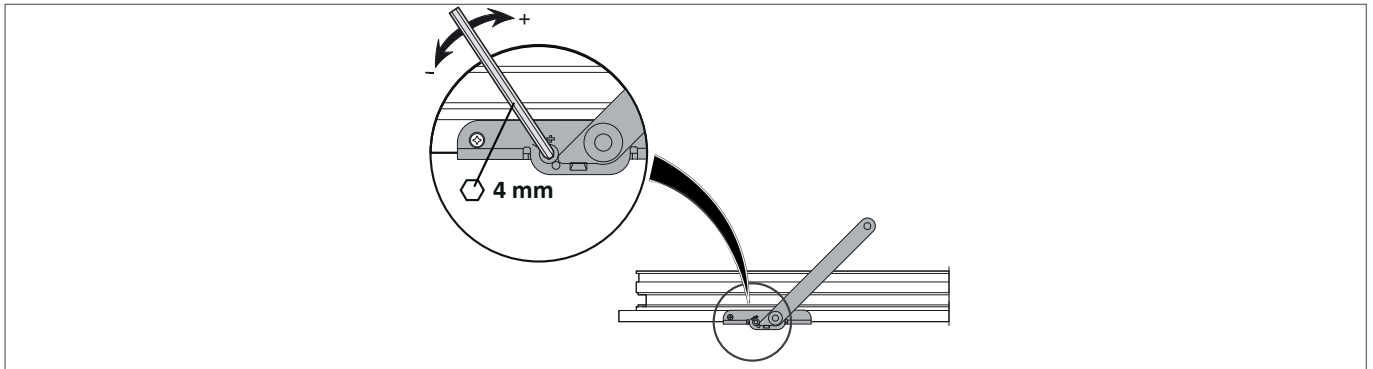

Adjust the engaging function of the tilt stay with Allen key SW 4: turn in clockwise direction stronger (+), turn in anticlockwise direction weaker (-).

5.2 Elevating adjustment of the bogie wheels



A regulation of the elevating adjustment must be undertaken following the installation of the element in the object in case of need.

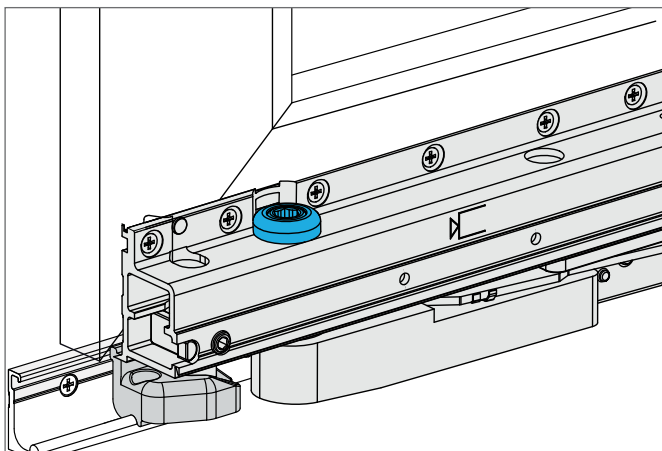

Height adjustment on the bogie wheels with Allen key SW 8.

Default setting in minimum position (0 mm)

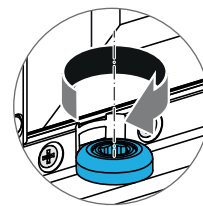
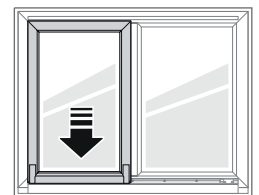
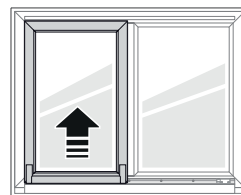

8 mm

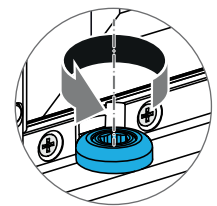

The maximum adjustment range must not be exceeded.

One rotation is equivalent to 1 mm height adjustment.
Maximum adjustment: 4 mm

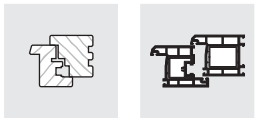

6 Profile cross-sections

6.1 Vertical cross-section, top

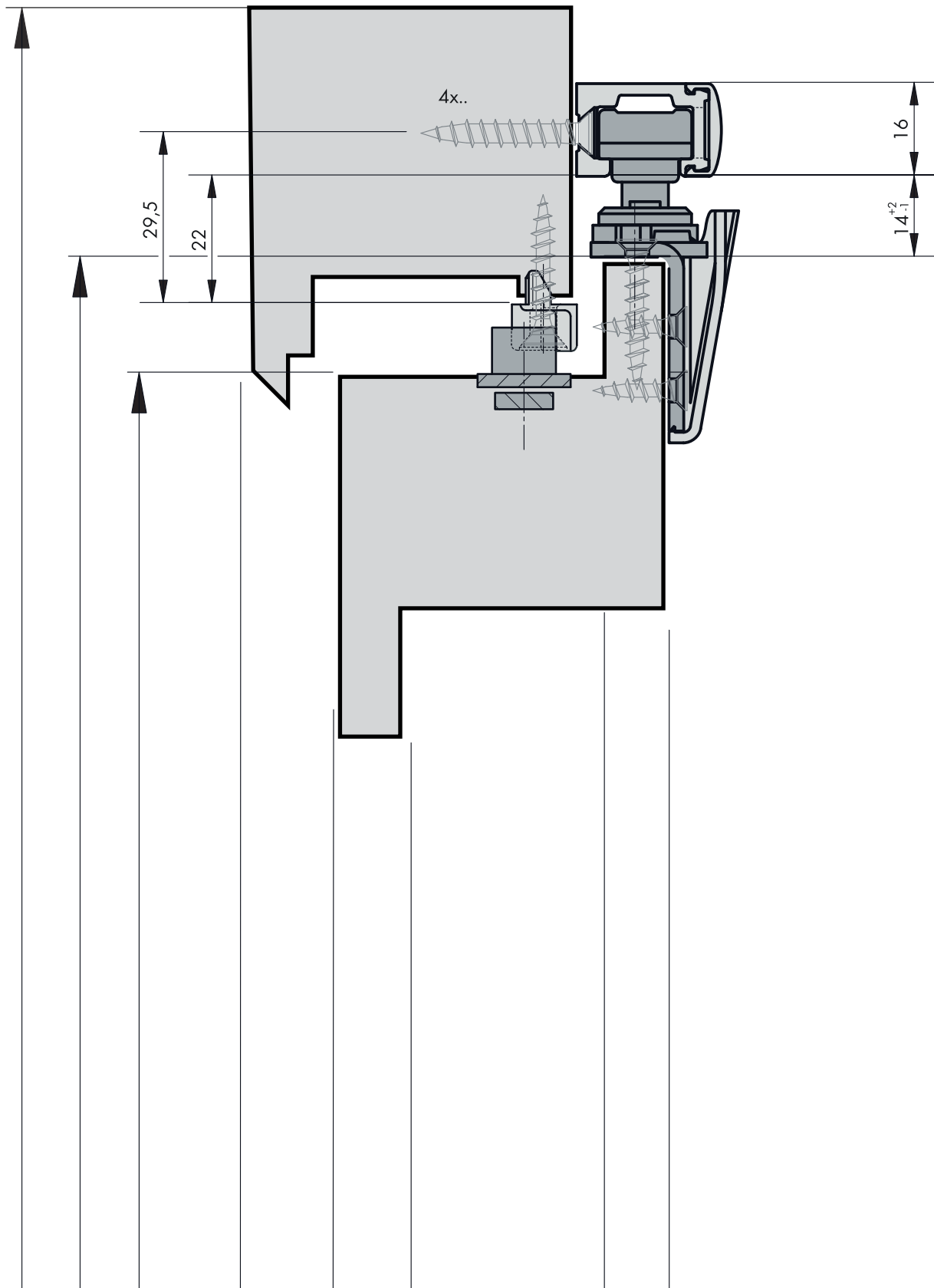

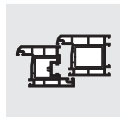

6.2 Vertical cross-section bottom

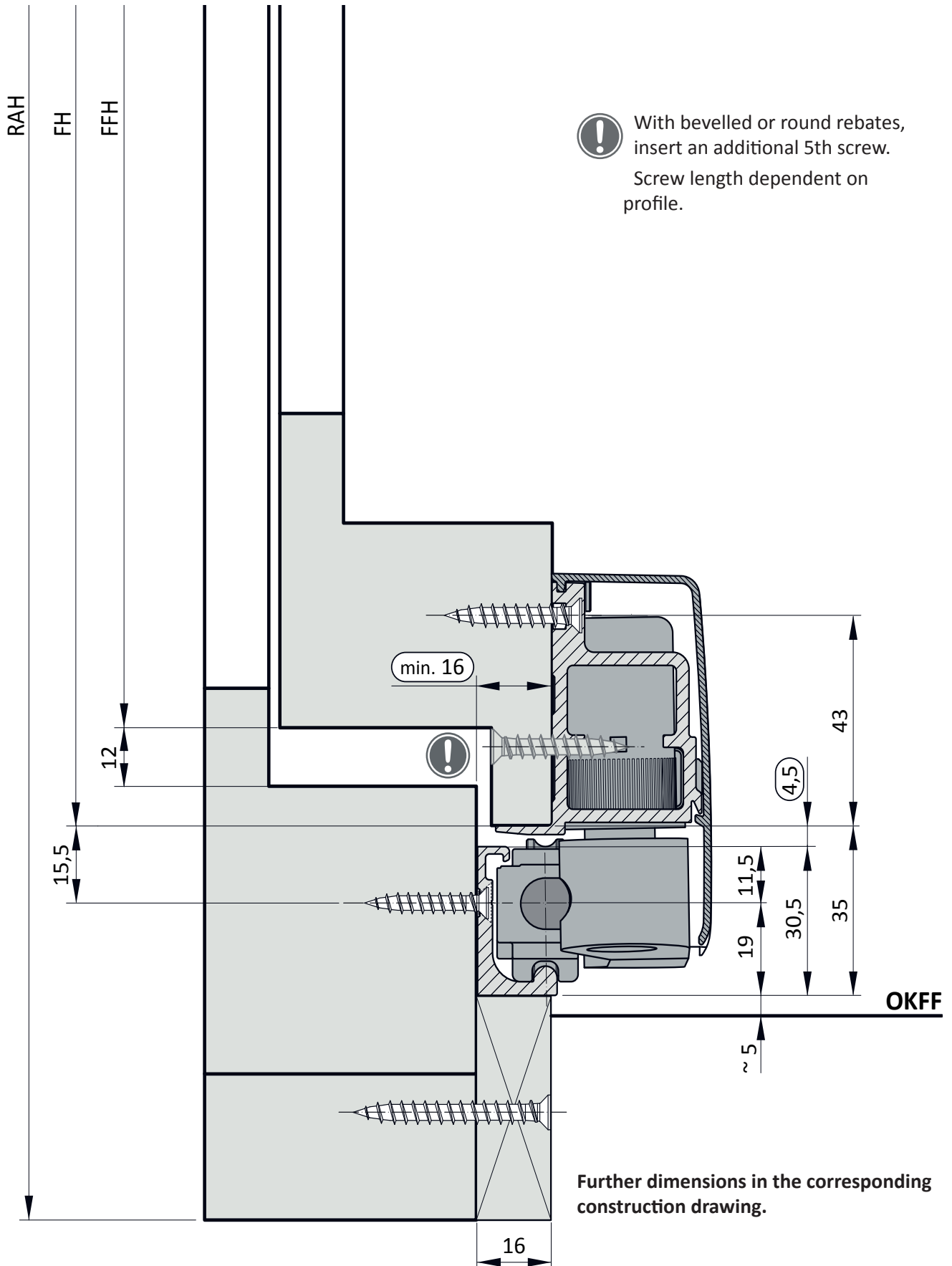

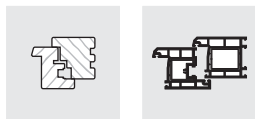

7 Jigs

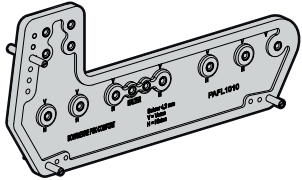
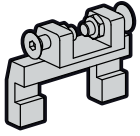
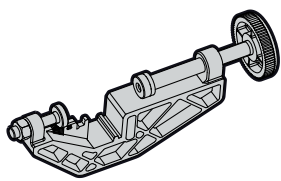
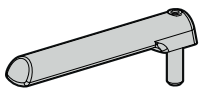
	Material description	Tooling	Material number
	<p>PSK Comfort jig</p> <p>for bogie wheels</p>		PAFL1010-09601_
	<p>PSK COMFORT jig locking part</p> <p>for locking parts</p>		PAEL1010-00001_
	<p>PSK Comfort clamping jig</p> <p>for running and guiding rail</p>		PALJ0110-02101_
	<p>PSK EB 640/4 jig</p> <p>For drill centring for fixing bore holes on guiding and running rail</p>	Drill Ø3	143001

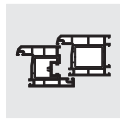

8 Feedback on documentation

We welcome your comments and suggestions on how to improve our documentation. Please email your comments to dokumentation@siegenia.com.

www.siegenia.com



SIEGENIA[®]
brings spaces to life