

# AERO

## AEROMAT flex

Facade ventilator for horizontal or vertical installation in timber, PVC or aluminium windows, in the wall connection joint.

Window systems

Door systems

Comfort systems

## Content

<b>1</b>	<b>SAFETY .....</b>	<b>3</b>
1.1	Target group of this documentation .....	3
1.2	Safety notes .....	3
1.3	Intended use .....	3
1.4	Improper use.....	3
<b>2</b>	<b>GENERAL NOTES.....</b>	<b>4</b>
2.1	Measuring unit.....	4
2.2	Function .....	4
<b>3</b>	<b>SCOPE OF DELIVERY .....</b>	<b>4</b>
<b>4</b>	<b>ASSEMBLY.....</b>	<b>5</b>
4.1	Size range .....	5
4.2	Required assembly material.....	5
4.3	Assembly sequence.....	6
4.3.1	Assembly of the weather grille.....	6
4.3.2	Optional: mounting the insect screen and weather grille.....	6
4.3.3	Installation of AEROMAT flex.....	6
<b>5</b>	<b>OPERATION.....</b>	<b>12</b>
<b>6</b>	<b>MAINTENANCE .....</b>	<b>13</b>
6.1	Cleaning .....	13
<b>7</b>	<b>ACCESSORIES.....</b>	<b>13</b>
<b>8</b>	<b>TECHNICAL SPECIFICATIONS .....</b>	<b>14</b>
8.1	Air throughput .....	14
8.2	Sound absorption.....	14
<b>9</b>	<b>DIMENSIONS .....</b>	<b>15</b>

## 1 Safety

### 1.1 Target group of this documentation

- This documentation is intended for use by specialists and end users.
- All instructions concerning assembly described in this document are to be performed exclusively by experienced professionals with training and practice in the assembly, commissioning, servicing and maintenance of decentralised ventilation units.
- All notes on operation and maintenance as well as the rectification of malfunctions described here are intended for specialists and end users.

### 1.2 Safety notes

- Comply with the safety regulations for operating electrical equipment and, if necessary, for ladders, steps and work overhead or at certain heights.

### 1.3 Intended use

- AEROMAT flex is a passive facade ventilator for the ventilation of closed rooms that works by equalising pressure between indoor and outdoor air (pressure differential principle).
- The assembly must be carried out in accordance with the installation and planning documents and state-of-the-art technology.
- Make sure that air can flow in and out at the air inlet and air outlet openings without impedance. Do not hang any textiles or paper or similar items over the air inlet and outlet openings and do not place any objects directly in front of or next to the unit. Do not insert any objects into the openings of the unit.

- AEROMAT flex in connection with motorised ventilation units is suitable as an outlet for exhaust and supply air flow:

- pressure differentials depending on the air humidity must be observed.

- Extreme weather conditions could lead to the following impairments:

- condensate formation (this is a physical effect and does not indicate a defect)
- restrictions of the function
- increased noise development

- AEROMAT flex is only to be used if it is in a technically sound condition, and no modifications may be made to the unit and/or its components.

- Keep ventilation openings free and do not block them with furniture or other objects.
- Use the AEROMAT flex only with original accessories from SIEGENIA.
- In the event of a fault, have AEROMAT flex checked and repaired by experienced specialists only.

### 1.4 Improper use

- Any use or application of this product that is not in accordance with its intended use, or any adaptation of or modification to the product and its associated components, for which the express consent of SIEGENIA has not been obtained, are strictly prohibited. SIEGENIA accepts no liability whatsoever for any material losses or injury to people caused by failure to comply with this stipulation.

## 2 General notes

### 2.1 Measuring unit

- All the dimensions in this documentation are specified in millimetres (mm).

### 2.2 Function

- The AEROMAT flex is a passive facade ventilator for the ventilation of closed rooms that works by equalising pressure between indoor and outdoor air (pressure differential principle).

- AEROMAT flex HY / AEROMAT flex HY 3F: the supply air opening is regulated by the relative humidity. Multilayer fabric belts react to any changes in the relative humidity in the room by expanding or contracting. This movement changes the supply air inlet via a control mechanism.

	AEROMAT flex HY 3F	AEROMAT flex HY	AEROMAT flex
Humidity control	●	●	–
Rotary switch	●	–	●
H: control based on the air humidity	●	–	–
1: closure locked whilst maintaining the minimum ventilation	●	–	●
2: locking mechanism of the maximum air flow rate	●	–	●

## 3 Scope of delivery

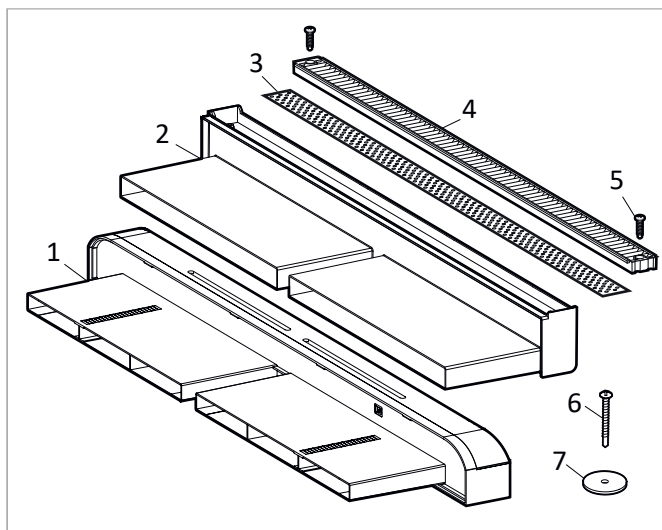

Item	Name	Quantity
1	Inside canal	1
2	Outside canal	1
3	Insect screen	1
4	Weather grille	1
5	Screw ø 2.9 x 13	2
6	Screw ø 4.2 x 38	1
7	Washer ø 28	1

## 4 Assembly

### 4.1 Size range

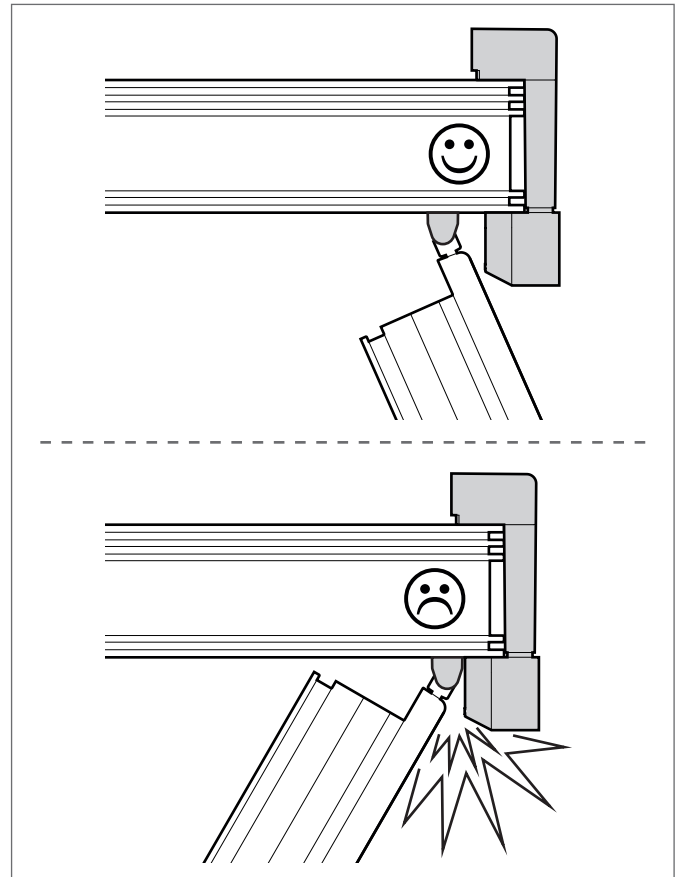
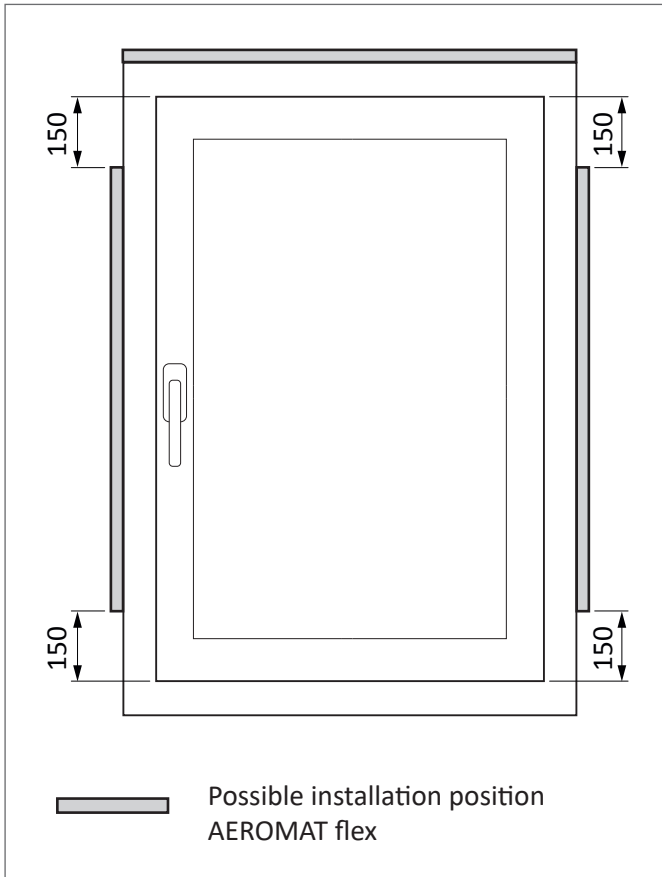

Adjust the wall connection to the geometry of the AEROMAT flex if necessary.



For installation on the hingeside, ensure that the AEROMAT flex does not collide with the opened window sash.

### 4.2 Required assembly material

a	Pre-compressed joint sealing tape for joint widths up to min. 5 mm
b	Weather-resistant adhesive tape
c	Weather-resistant double-sided adhesive tape
d	Multifunctional sealing tape for joint width up to min. 8 mm
e	Multifunctional sealing tape for joint width up to min. 25 mm



Install and seal AEROMAT flex RAL conformant and in accordance with state-of-the-art technology.



Alternative installation recommendation for sealing with joint sealing sheet and injectable joint sealing compound (joint foam) is possible according to RAL.

### 4.3 Assembly sequence

#### 4.3.1 Assembly of the weather grille

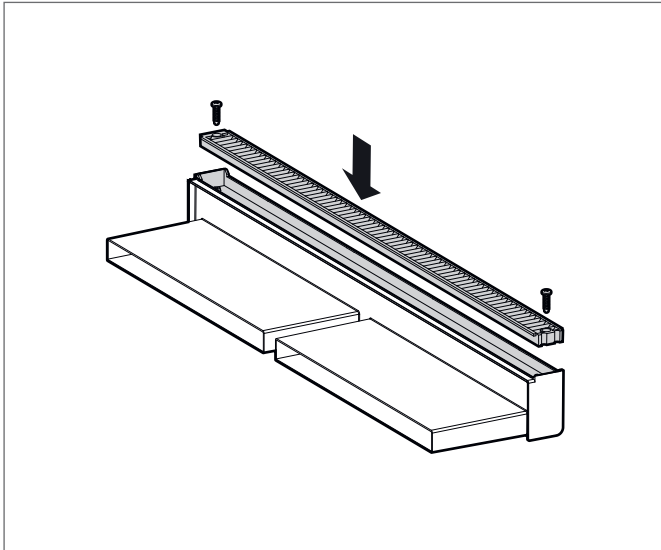

Insert the weather grille and fix with screws

#### 4.3.2 Optional: mounting the insect screen and weather grille

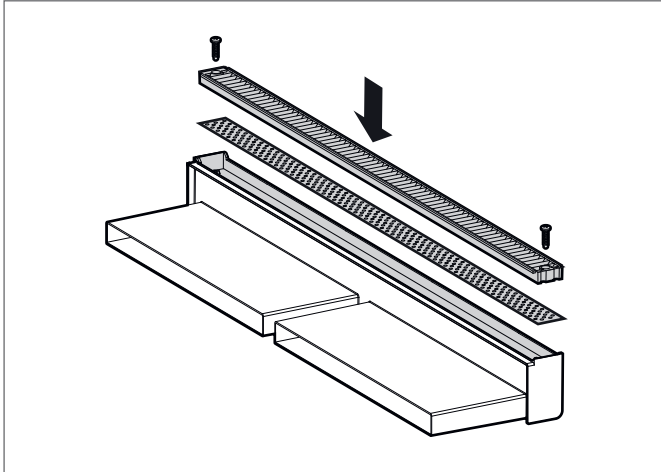

Insert the insect screen and weather grille and fix with screws

#### 4.3.3 Installation of AEROMAT flex

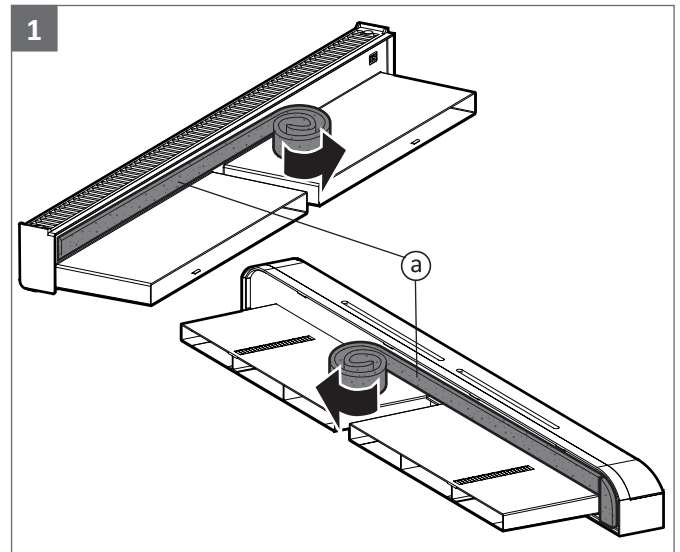

Apply pre-compressed joint sealing tape (a) (for joint width up to min. 5 mm) to the inner surfaces of the outside canal and the inside canal

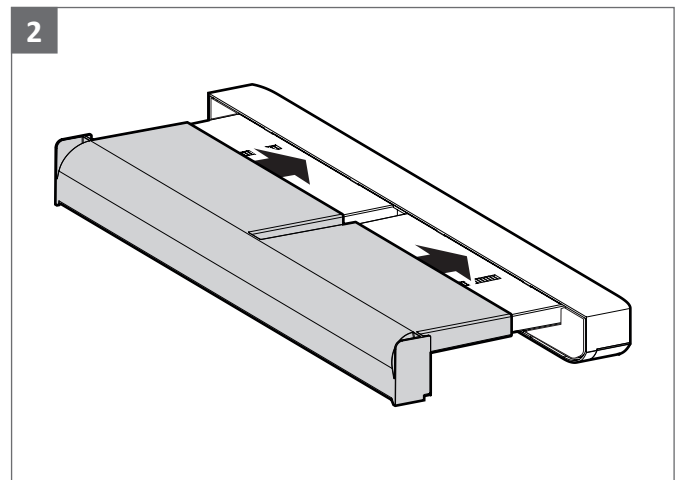

Slide the outside canal onto the inside canal

3



Allowed

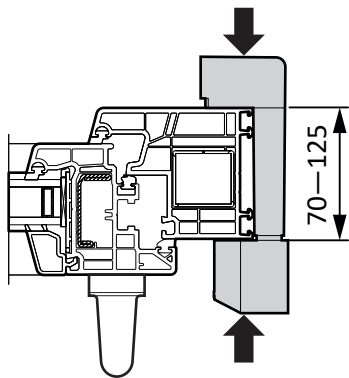

Prohibited

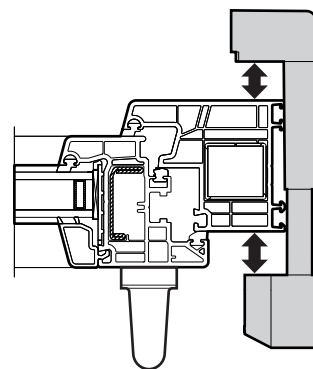
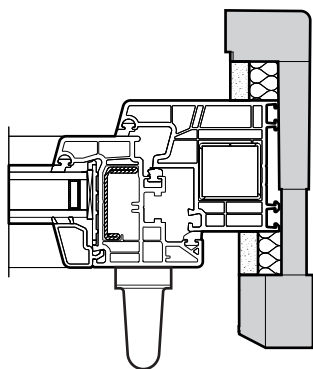
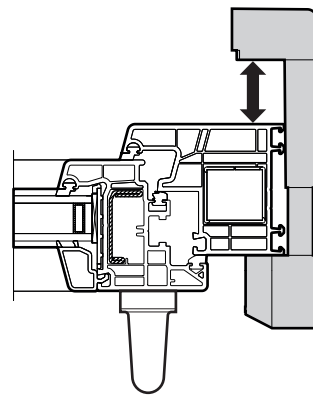
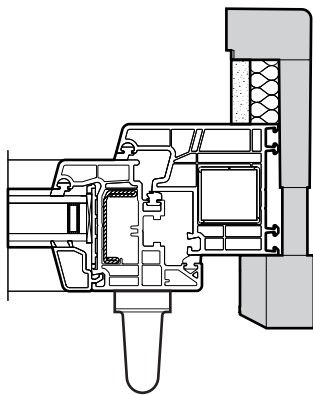
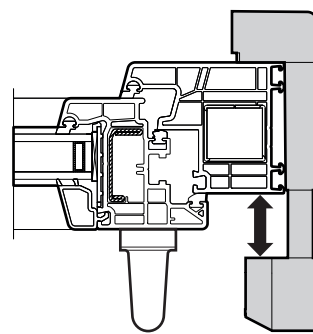
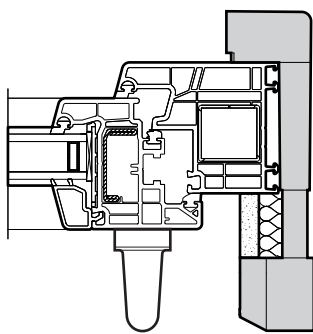

Adapt canal depth to the window frame

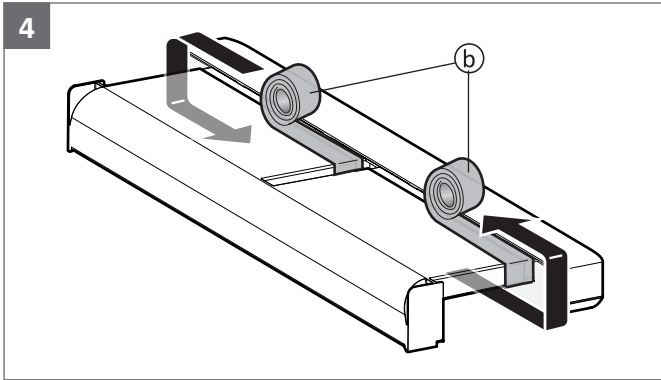

Fix the outside canal and inside canal circumferentially with weather-resistant adhesive tape (b)

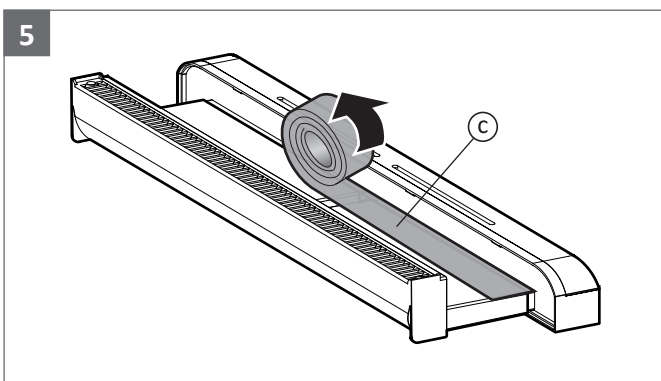

Fix weather-resistant double-sided adhesive tape (c) to the inside of the canal

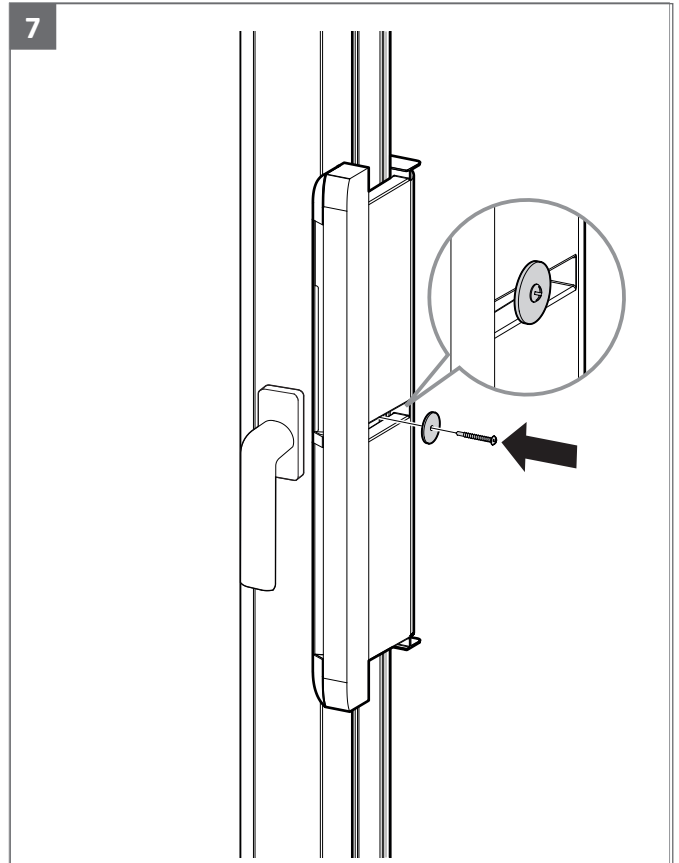

Optional: fix the AEROMAT flex to the frame additionally with a screw and washer.

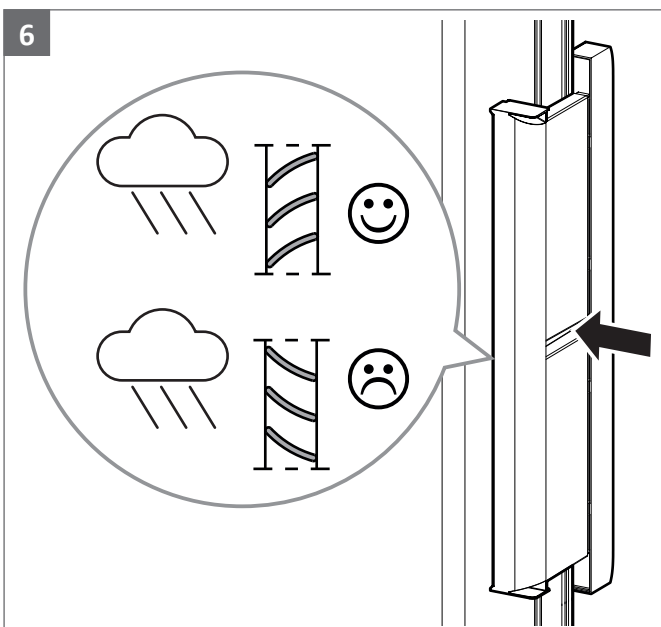

Position AEROMAT flex on the window frame and press firmly into place



For vertical installation, ensure that the lamella of the weather grille are facing downwards. If necessary, the weather grille must be screwed on rotated by 180°.

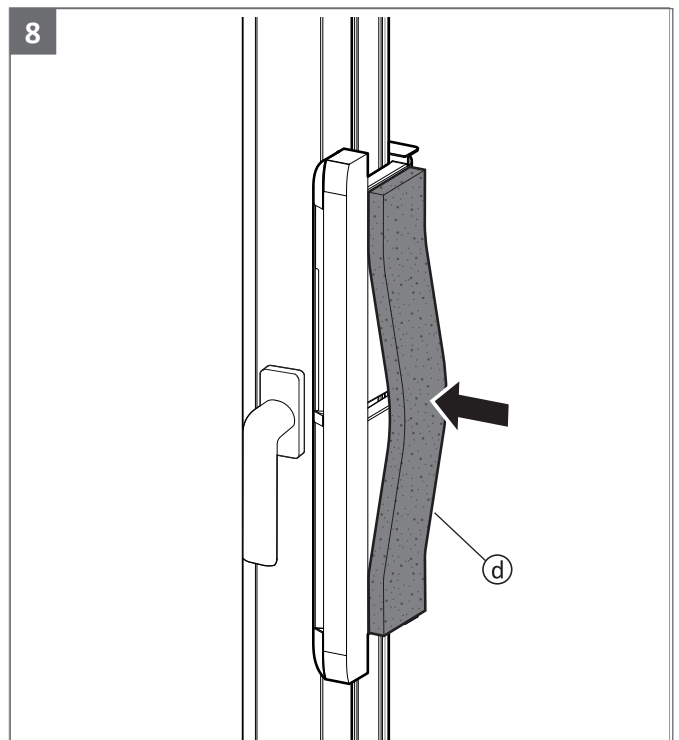

Apply multifunctional sealing tape (d) (for joint width up to min. 8 mm) to the AEROMAT flex

9

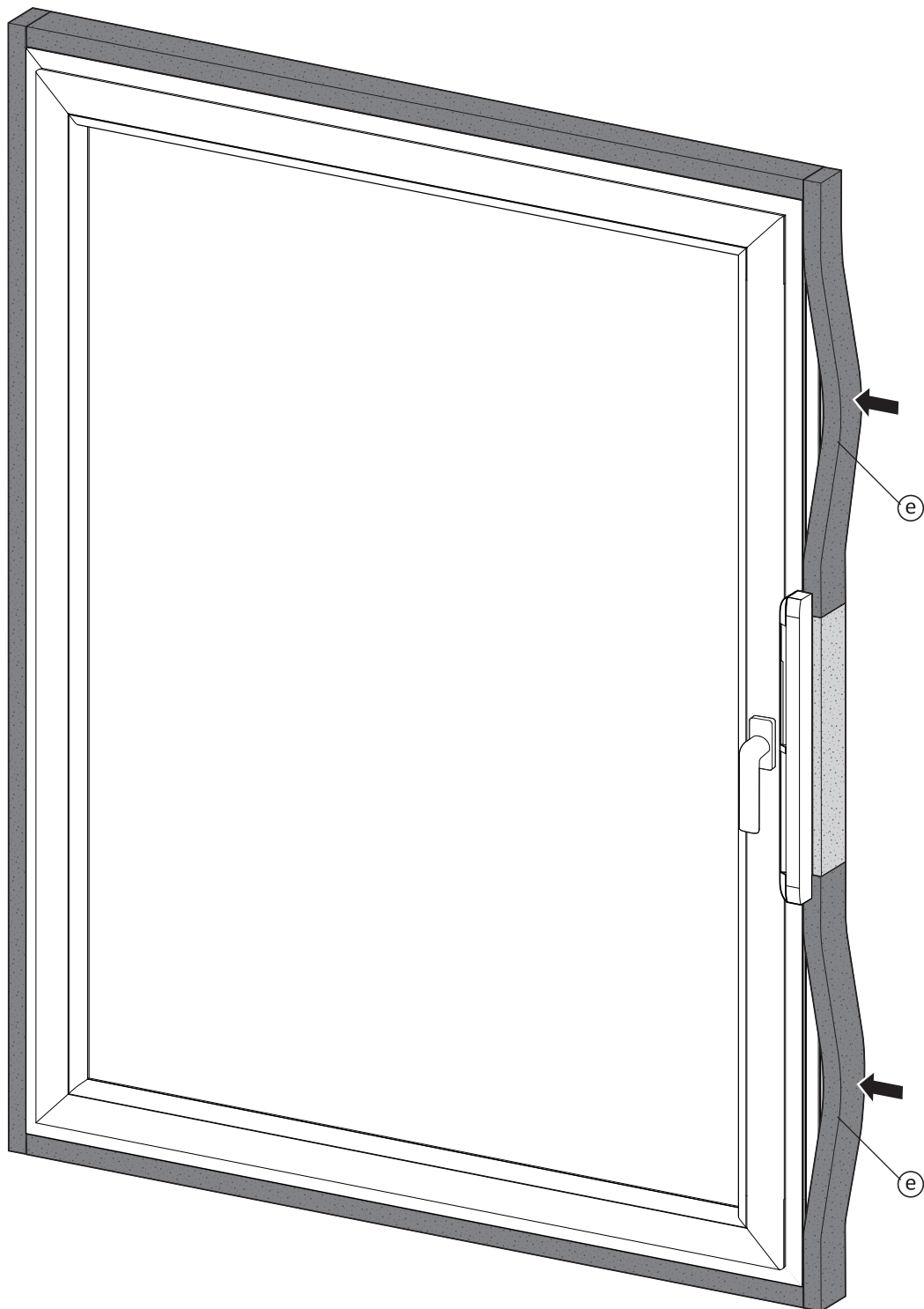

Apply multifunctional sealing tape © (for joint width up to min. 25 mm) circumferentially to the window frame

10

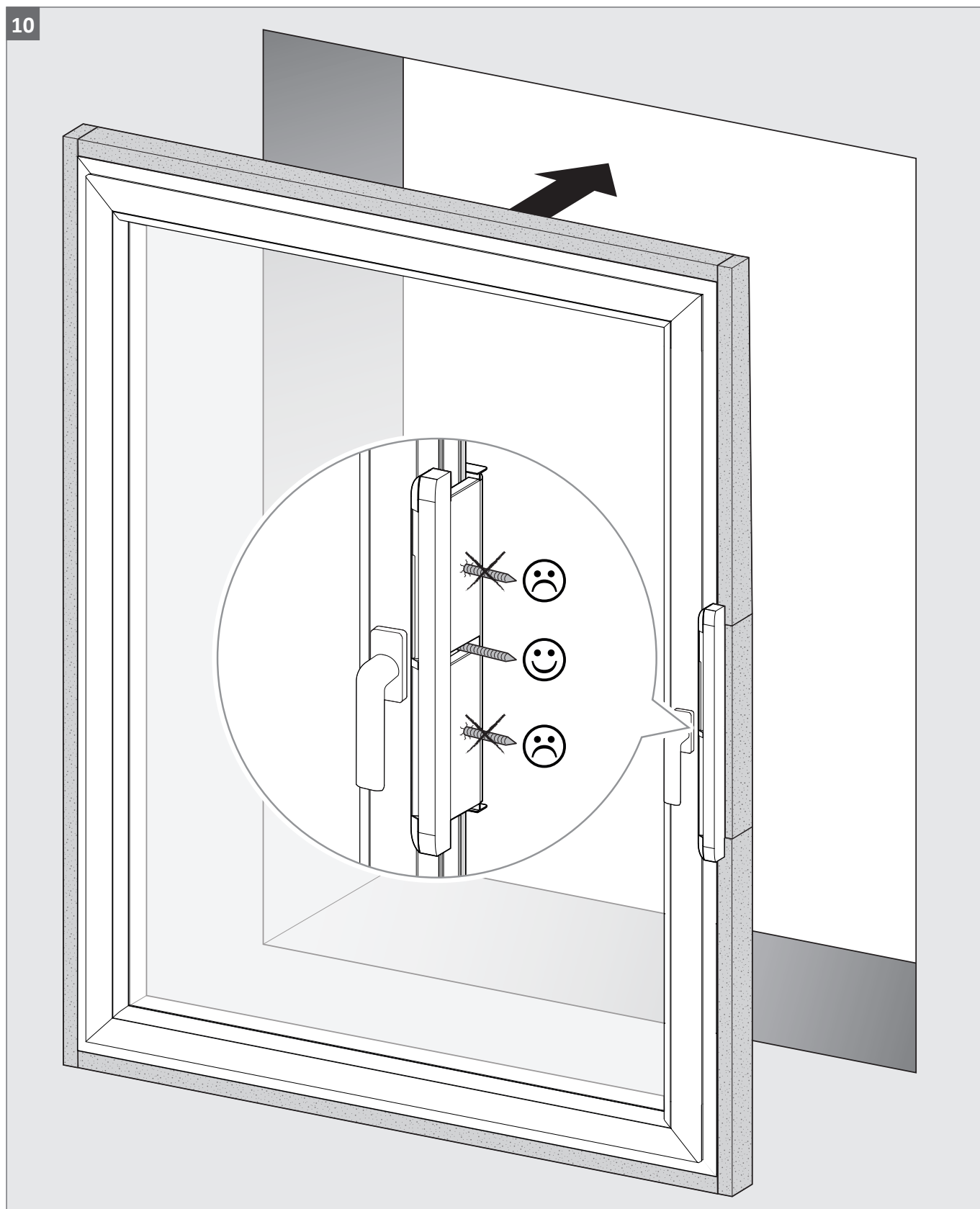

Insert window with AEROMAT flex into the wall opening and fix the window to the wall



If necessary, a screw can be screwed in between the two air ducts.

Make sure that you do not drill through the air duct!

11

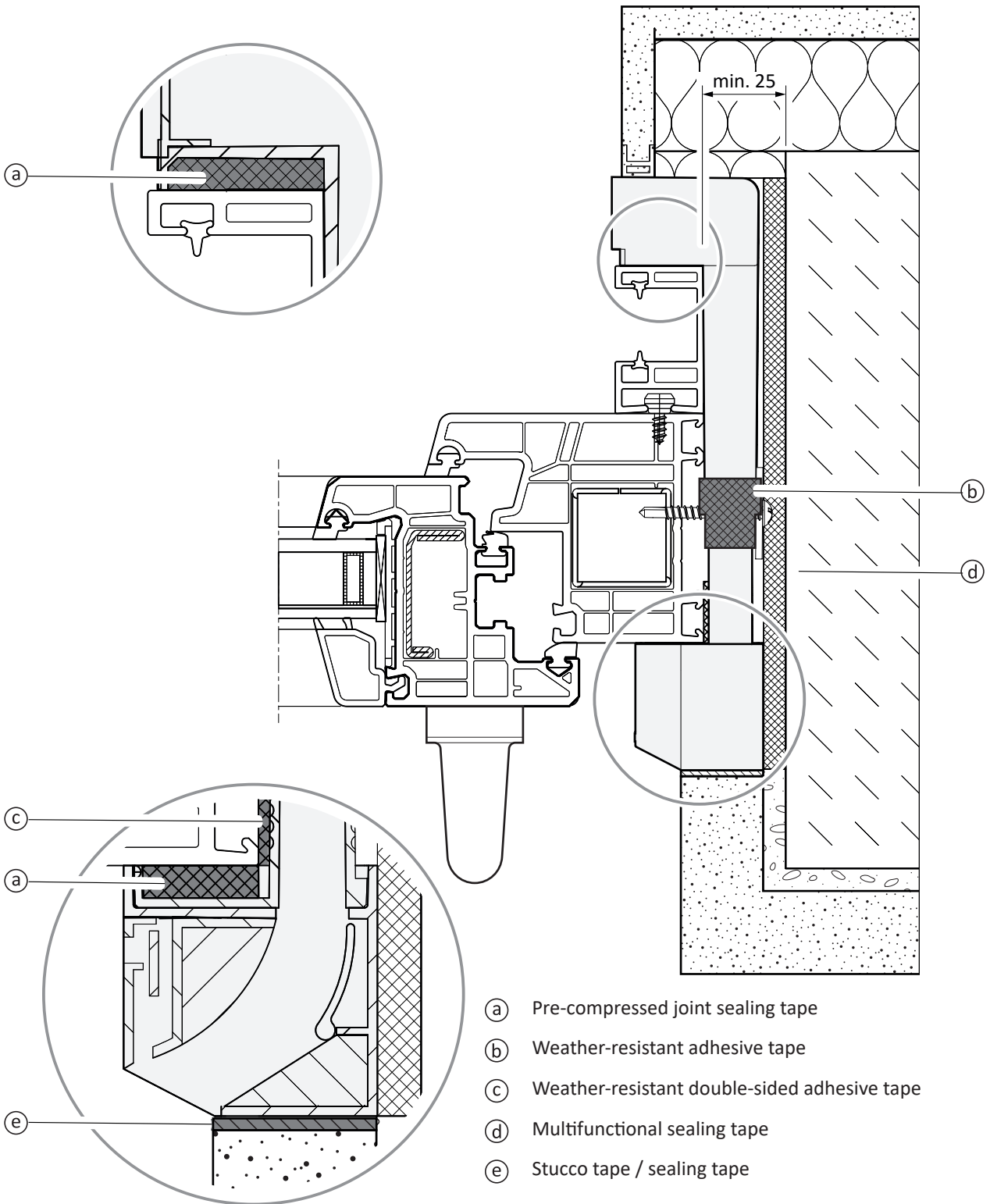

Plastering and insulating from outside (see figure for installation recommendation)



AEROMAT flexProtect the inside and outside of the ventilation openings from contamination during installation.



You can find further installation suggestions under:  
<https://www.siegenia.com/en/service/doc/H43.FENS003>

5 Operation

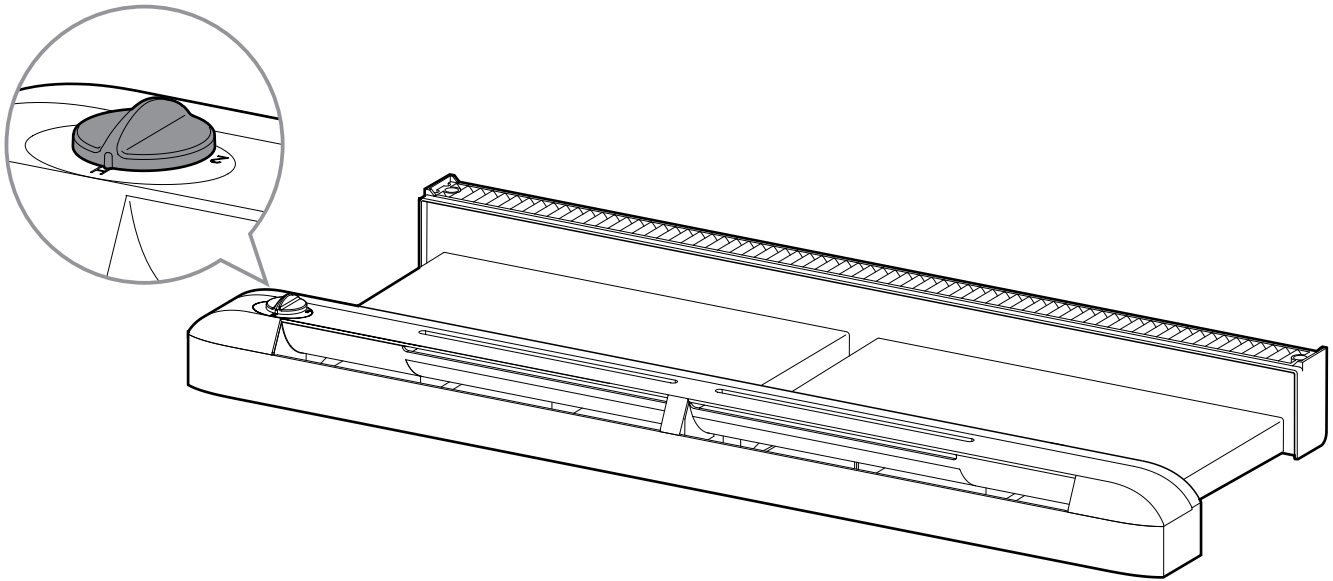

	AEROMAT flex HY 3F	AEROMAT flex HY	AEROMAT flex
<p><b>Humidity control (H):</b> control based on the air humidity</p>		<p><b>No rotary switch</b> The control is always dependent on the air humidity</p>	<p>—</p>
<p><b>Air throughput min. (1):</b> closure locked whilst maintaining the minimum ventilation</p>		<p>—</p>	
<p><b>Air throughput max. (2):</b> locking mechanism maximum air flow rate</p>		<p>—</p>	

## 6 Maintenance

### 6.1 Cleaning

- Never use cleaning agents that are aggressive or contain solvents, or sharp-edged objects, as these may damage the surfaces of the casing.
- Never clean the unit with a high-pressure cleaner or steam-jet cleaner.
- Clean the AEROMAT flex with a cloth moistened with a mild soap solution or cleaning agent.

## 7 Accessories

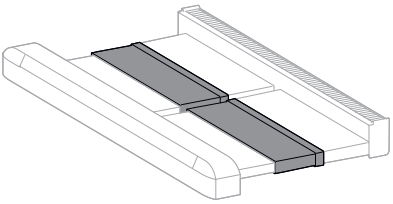
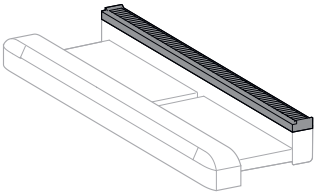
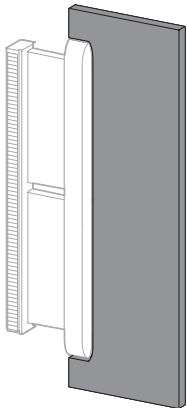
	Material description	Material number	Colour	VE
	Extension canal set	L4281400-004120	white (similar to RAL 9016)	5 piece
	Sound insulation module*	L4281300-004120	white (similar to RAL 9016)	5 piece
	Reveal extension	L4281410-004020	white (similar to RAL 9016)	10 piece
	Plastering strip	L4281500-004120	–	5 piece

\*max. 3 pieces per unit

## 8 Technical specifications

### 8.1 Air throughput

	Air throughput min. (1)	Ait throughput max. (2)	Humidity control (H) <sup>1)</sup>
<b>AEROMAT flex</b>	●	●	–
<b>AEROMAT flex HY</b>	–	–	●
<b>AEROMAT flex HY 3F</b>	●	●	●
<b>Air throughput <sup>2)</sup></b>			
at 2 Pa	1 m <sup>3</sup> /h	14 m <sup>3</sup> /h	1–14 m <sup>3</sup> /h
at 4 Pa	2 m <sup>3</sup> /h	20 m <sup>3</sup> /h	2–20 m <sup>3</sup> /h
at 5 Pa	2 m <sup>3</sup> /h	23 m <sup>3</sup> /h	2–23 m <sup>3</sup> /h
at 7 Pa	3 m <sup>3</sup> /h	28 m <sup>3</sup> /h	3–28 m <sup>3</sup> /h
at 8 Pa	3 m <sup>3</sup> /h	30 m <sup>3</sup> /h	3–30 m <sup>3</sup> /h
at 10 Pa	3 m <sup>3</sup> /h	33 m <sup>3</sup> /h	3–33 m <sup>3</sup> /h
at 20 Pa	5 m <sup>3</sup> /h	48 m <sup>3</sup> /h	5–48 m <sup>3</sup> /h

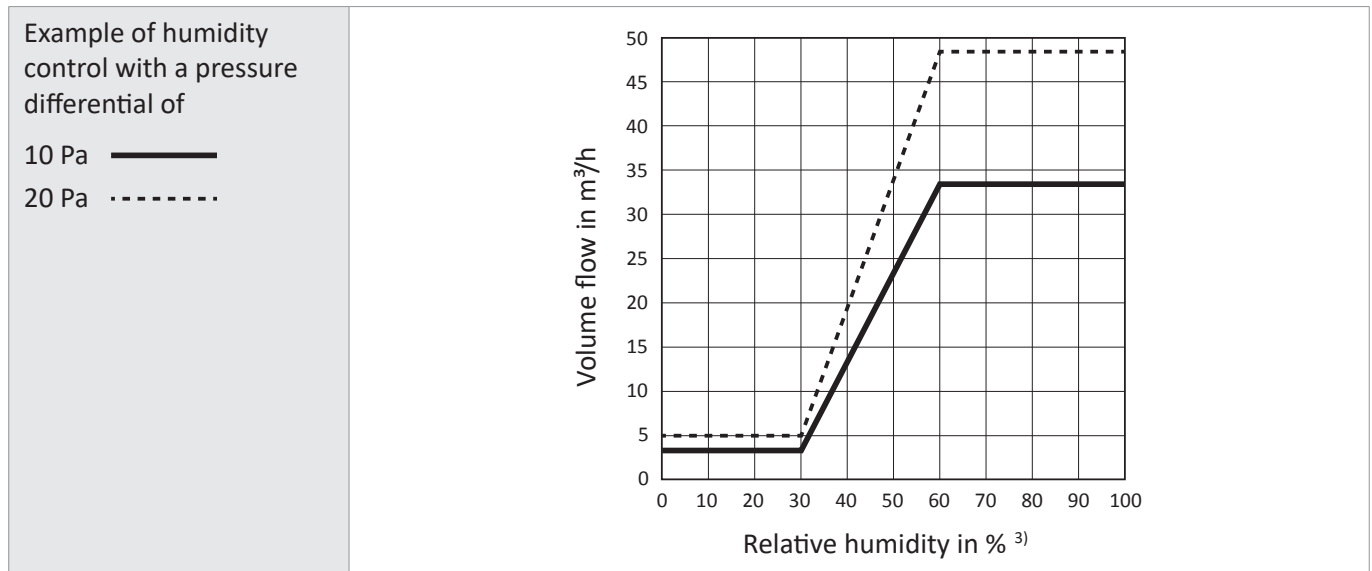

<sup>1)</sup> Relative air humidity ≤ 30 % = air throughput min.; air humidity ≥ 60 % = air circulation max.

<sup>2)</sup> measured according to DIN EN 13141-1

<sup>3)</sup> The measuring tolerance of the air humidity is ± 5 %

### 8.2 Sound absorption

Number of extension canal sets	0	0	1	2
<b>Canal depth</b>	90 mm	125 mm	180 mm	235 mm
<b>Sound absorption <math>D_{n,e,w}</math> <sup>4,5</sup> (up to)</b>				
with 0 sound insulation modules	36 dB	41 dB	41 dB	42 dB
with 1 sound insulation module	41 dB	47 dB	48 dB	50 dB
with 2 sound insulation modules	43 dB	49 dB	50 dB	52 dB
with 3 sound insulation modules	44 dB	51 dB	53 dB	55 dB

<sup>4)</sup> measured in accordance with DIN EN 10140-2

<sup>5)</sup> The sound absorption reduces itself in accordance with shorter lengths of the telescopic canal.

9 Dimensions

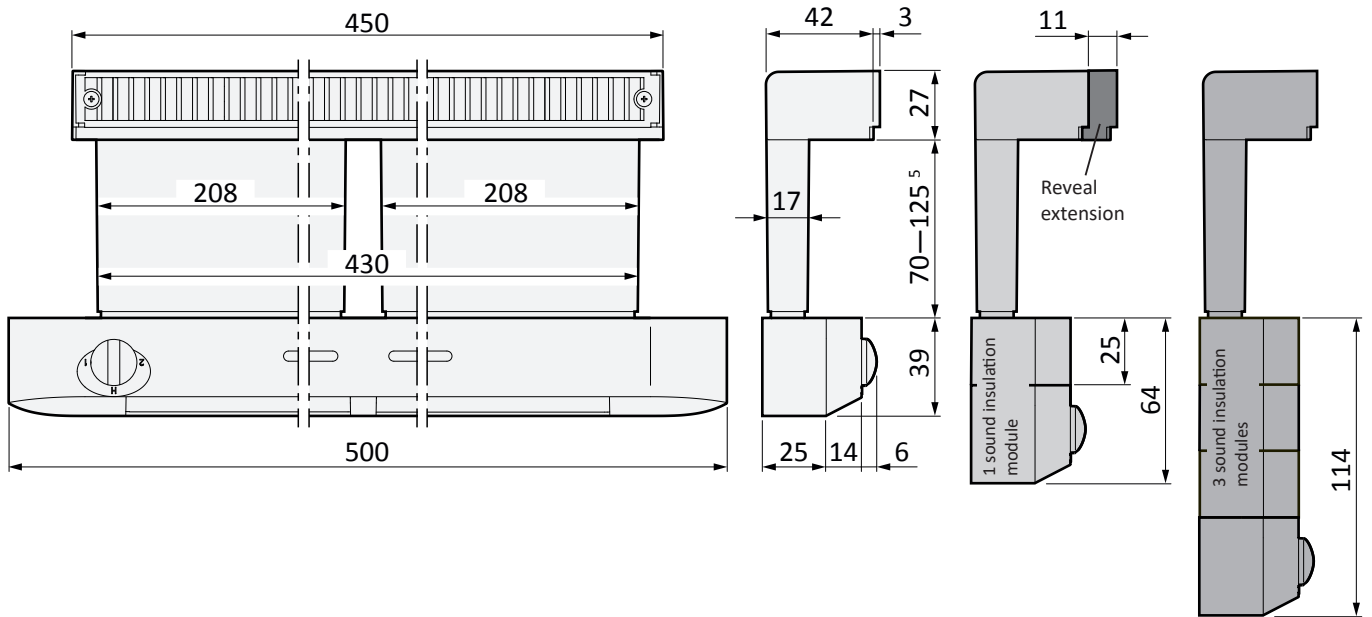

<sup>5)</sup> Canal extendable from 70 mm to 125 mm without extension canal set  
 Canal extendable from 125 mm to 180 mm with one extension canal set  
 Canal extendable from 180 mm to 235 mm with two extension canal sets

[www.siegenia.com](http://www.siegenia.com)



**SIEGENIA®**  
brings spaces to life